

TOSHIBA CCD Linear Image Sensor CCD (charge coupled device)

TCD1304DG

TOSHIBA CCD Linear Image Sensor CCD (charge coupled device)

TCD1304DG

The TCD1304DG is a high sensitive and low dark current 3648 elements linear image sensor. The sensor can be used for POS scanner.

The device consist of sensitivity CCD chip.

The TCD1304DG has electronic shutter function (ICG).

Electronic shutter function can keep always output voltage constant that vary with intensity of lights.

FEATURES

- Pixel Number : 3648
- Pixel Size : 8μm×200μm (8μm pitch)
- Photo Sensing Region : High Sensitive & Low Dark Current pn Photodiode
- Internal Circuit : CCD Drive Circuit
- Power Supply : Only 3.0V Drive (MIN)
- Function : Electronic Shutter
Sample and Hold Circuit
- Package : 22 Pin CERDIP

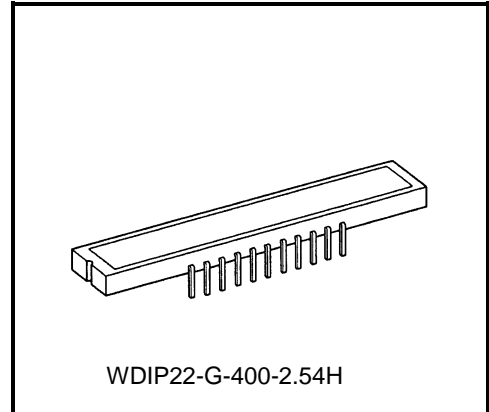

Weight: (3.5g (Typ.))

ABSOLUTE MAXIMUM RATINGS (Note 1)

CHARACTERISTIC	SYMBOL	RATING	UNIT
Master Clock Pulse Voltage	$V_{\phi M}$	-0.3 to +7.0	V
SH Pulse Voltage	V_{SH}		
ICG Pulse Voltage	V_{ICG}		
Digital Power Supply	V_{DD}		
Analog Power Supply	V_{AD}		
Operating Temperature	T_{opr}	-25 to +60	°C
Storage Temperature	T_{stg}	-40 to +100	°C

Note: All voltage are with respect to SS terminals. (Ground)
 None of the ABSOLUTE MAXIMUM RATINGS must be exceeded, even instantaneously.
 If any one of the ABSOLUTE MAXIMUM RATINGS is exceeded, the electrical characteristics, reliability and life time of the device cannot be guaranteed.
 If the ABSOLUTE MAXIMUM RATINGS are exceeded, the device can be permanently damaged or degraded.
 Create a system design in such a manner that any of the ABSOLUTE MAXIMUM RATINGS will not be exceeded under any circumstances.

PIN CONNECTION

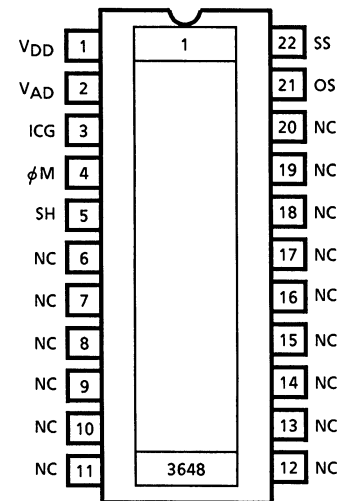

(TOP VIEW)

CIRCUIT DIAGRAM

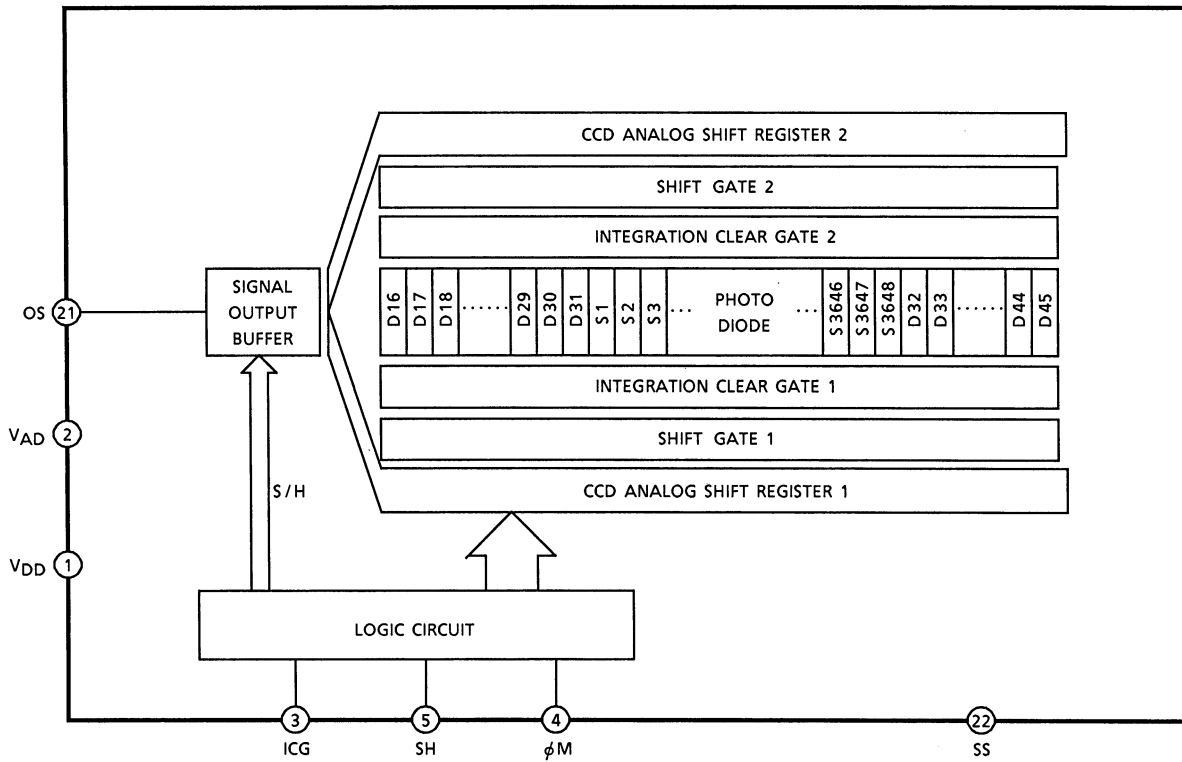

PIN NAMES

PIN No.	SYMBOL	NAME	PIN No.	SYMBOL	NAME
1	VDD	Power (Digital)	22	SS	Ground
2	VAD	Power (Analog)	21	OS	Output signal
3	ICG	Integration clear gate	20	NC	Non connection
4	φM	Master clock	19	NC	Non connection
5	SH	Shift gate	18	NC	Non connection
6	NC	Non connection	17	NC	Non connection
7	NC	Non connection	16	NC	Non connection
8	NC	Non connection	15	NC	Non connection
9	NC	Non connection	14	NC	Non connection
10	NC	Non connection	13	NC	Non connection
11	NC	Non connection	12	NC	Non connection

OPTICAL / ELECTRICAL CHARACTERISTICS

Ta = 25°C, V_φ = 4.0V (PULSE), f_{DATA} = 0.5MHz, t_{INT} (INTEGRATION TIME) = 10ms, V_{AD} = V_{DD} = 4.0V, LIGHT SOURCE = DAYLIGHT FLUORESCENT LAMP

CHARACTERISTIC	SYMBOL	MIN	TYP.	MAX	UNIT	NOTE
Sensitivity	R	110	160	—	V / lx·s	
Photo Response Non Uniformity	PRNU	—	—	10	%	(Note 1)
Register Imbalance	RI	—	—	3	%	(Note 2)
Saturation Output Voltage	V _{SAT}	450	600	—	mV	(Note 3)
Dark Signal Voltage	V _{MDK}	—	2	5	mV	(Note 4)
Total Transfer Efficiency	TTE	92	95	—	%	
Dynamic Range	DR	—	300	—	—	(Note 5)
Saturation Exposure	SE	—	0.004	—	lx·s	(Note 6)
DC Power Dissipation	PD	—	25	75	mW	
DC Signal Output Voltage	V _{OS}	1.5	2.5	3.5	V	(Note 7)
Output Impedance	Z _O	—	0.5	1.0	kΩ	
Image Lag of Electronic Shutter	V _{LAGICG}	—	—	10	mV	t _{INT} =100μs

Note 1: Measured at 50% of SE (Typ.)

Definition of PRNU:

$$PRNU = \frac{\Delta X}{\bar{X}} \times 100 (\%)$$

Where \bar{X} is average of total signal outputs and ΔX is the maximum deviation from \bar{X} under uniform illumination.

Note 2: Measured at 50% of SE (Typ.)

RI is defined as follows:

$$RI = \frac{\Delta Y}{\bar{X}} \times 100(\%)$$

Where \bar{X} is average of total signal output.

ΔY : | (average of odd signal output) – (average of even signal output) |

Note 3: V_{SAT} is defined as minimum saturation output voltage of all effective pixels. V_{AD}=V_{DD}=3.0V.

Note 4: V_{MDK} is defined as maximum dark signal voltage of all effective pixels.

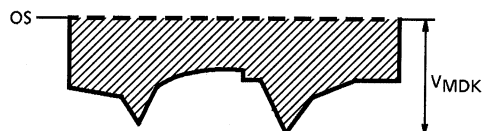

Note 5: Definition of DR : $DR = \frac{V_{SAT}}{V_{MDK}}$

VMDK is proportional to t_{INT} (Integration time).

So the shorter t_{INT} condition makes wider DR value.

Note 6: Definition of SE : $SE = \frac{V_{SAT}}{R} (I \cdot S)$

Note 7: DC signal output voltage is defined as follows:

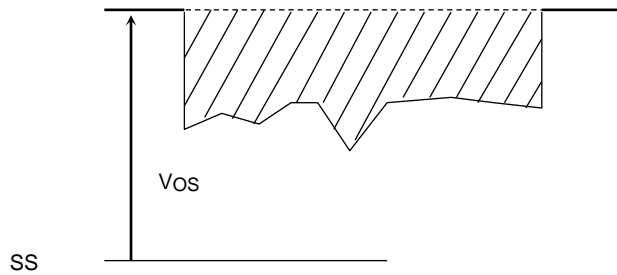

OPERATING CONDITIONS

For best performance, the device should be used within the Recommended Operating Conditions.

CHARACTERISTIC		SYMBOL	MIN	TYP.	MAX	UNIT
Master Clock Pulse Voltage	"H" Level	$V_{\phi M}$	3.0	4.0	5.5	V
	"L" Level		0	0	0.44	
SH Pulse Voltage	"H" Level	V_{SH}	3.0	4.0	5.5	V
	"L" Level		0	0	0.44	
ICG Pulse Voltage	"H" Level	V_{ICG}	3.0	4.0	5.5	V
	"L" Level		0	0	0.44	
Digital Power Supply		V_{DD}	3.0	4.0	5.5	V
Analog Power Supply		V_{AD}	3.0	4.0	5.5	V

Note: $V_{AD} = V_{DD}$

MAX Voltage of Pulse Voltage "H" Level = $V_{DD} = V_{AD}$

MIN. Voltage of Pulse Voltage "H" Level = $V_{DD} - 0.5V = V_{AD} - 0.5V$

CLOCK CHARACTERISTICS ($T_a = 25^\circ\text{C}$) ($V_{AD} = V_{DD} \geq 4.0V$)

For best performance, the device should be used within the Recommended Operating Conditions.

CHARACTERISTIC	SYMBOL	MIN	TYP.	MAX	UNIT
Master Clock Frequency	$f_{\phi M}$	0.8	2.0	4.0	MHz
Data Rate	f_{DATA}	0.2	0.5	1.0	MHz
Master Clock Capacitance	$C_{\phi M}$	—	10	—	pF
Shift Pulse Capacitance	C_{SH}	—	600	—	pF
ICG Pulse Capacitance	C_{ICG}	—	250	—	pF

CLOCK CHARACTERISTICS ($T_a = 25^\circ\text{C}$) ($3.0V \leq V_{AD} = V_{DD} < 4.0V$)

For best performance, the device should be used within the Recommended Operating Conditions.

CHARACTERISTIC	SYMBOL	MIN	TYP.	MAX	UNIT
Master Clock Frequency	$f_{\phi M}$	0.8	2.0	2.4	MHz
Data Rate	f_{DATA}	0.2	0.5	0.6	MHz

TIMING CHART

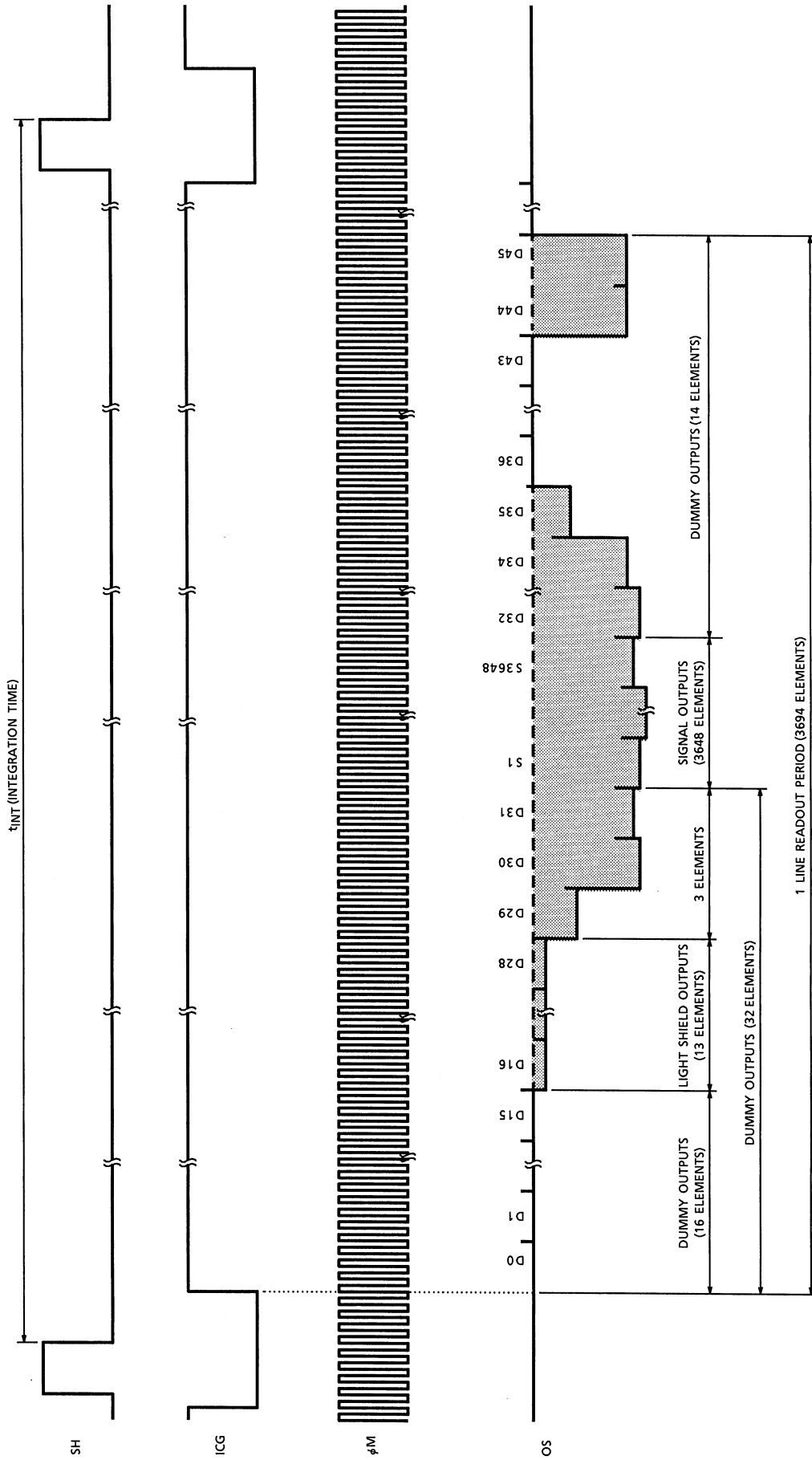

TCD1304DG-6

TIMING CHART (Use electronic shutter function)

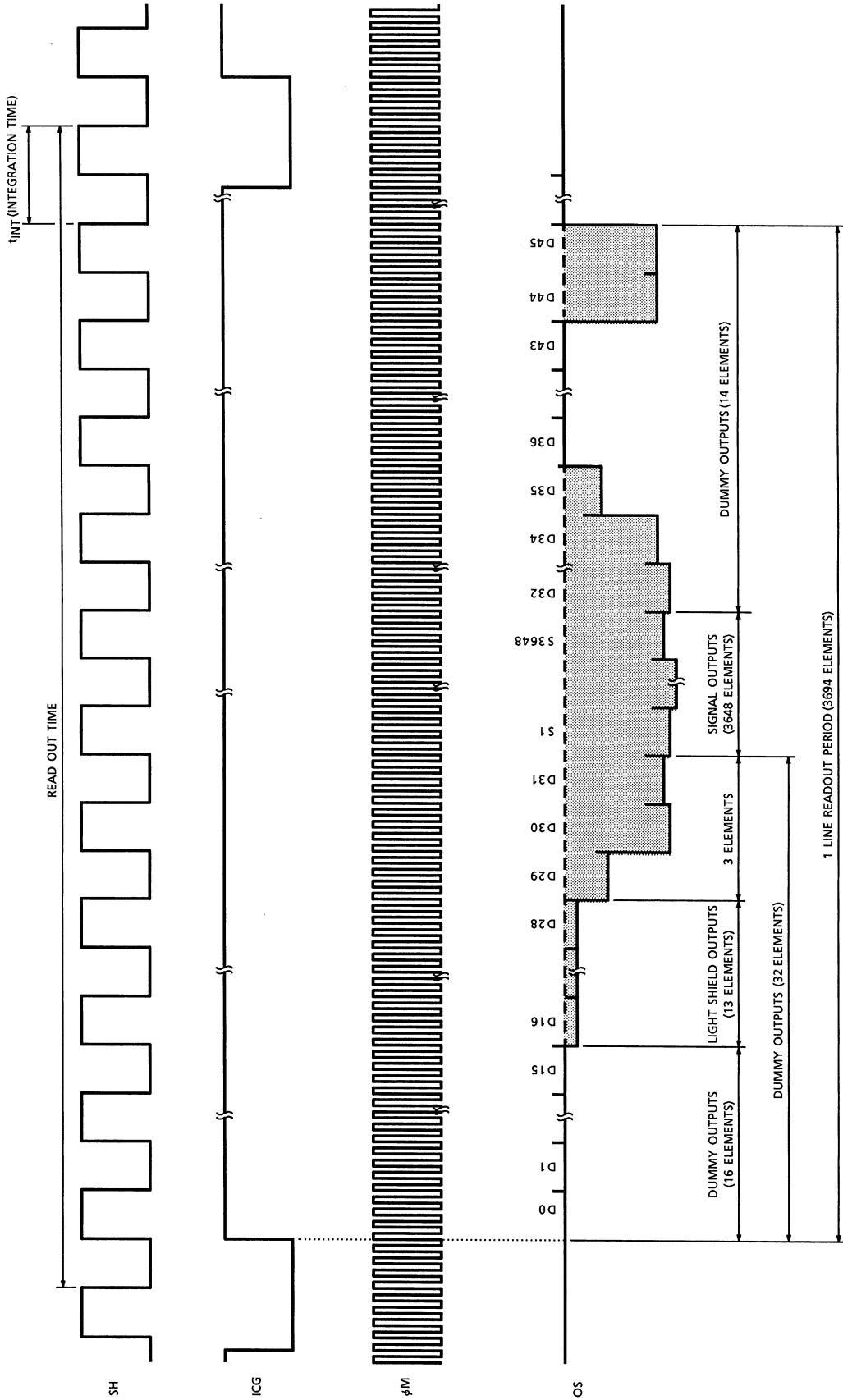

TCD1304DG-7

TIMING REQUIREMENTS

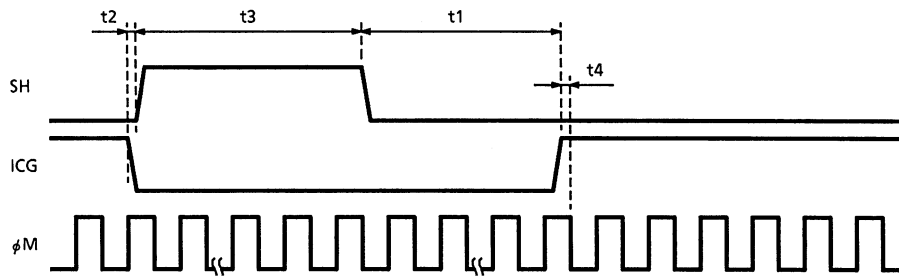

CHARACTERISTIC	SYMBOL	MIN	TYP.	MAX	UNIT
ICG Pulse Delay	t1	1000	5000	—	ns
Pulse Timing of ICG and SH	t2	100	500	1000	ns
SH Pulse Width	t3	1000	—	—	ns
Pulse Timing of ICG and φ M	t4	0	20	*	ns

*: You keep φM "High" Level.

USE ELECTRONIC SHUTTER

Pulse Timing of SH and ICG

- SH cycle = t_{INT}

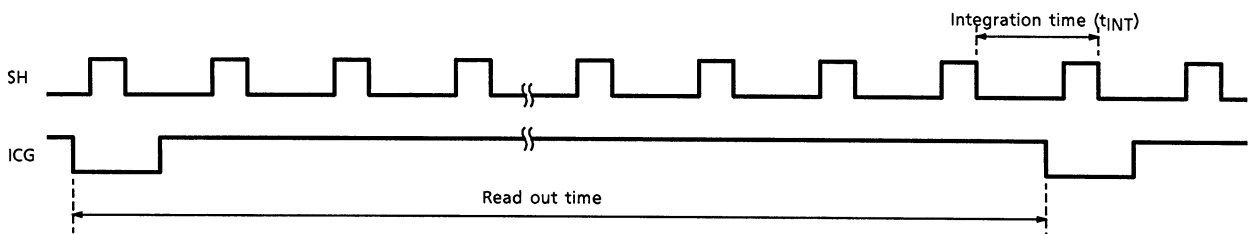

t_{INT} (MIN)=10μs

SH pulse width (t₃) should be kept constant.

The illumination of light source must be less than 1000 times of the 450mV output condition at t_{INT} = 10ms.

TYPICAL PERFORMANCE CURVES

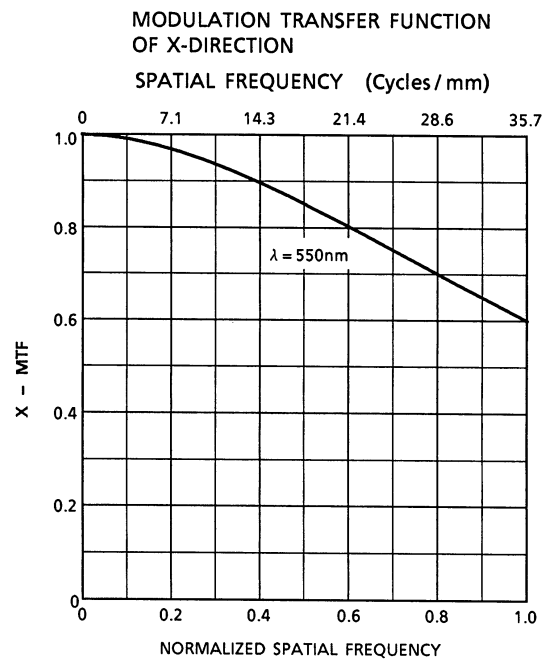
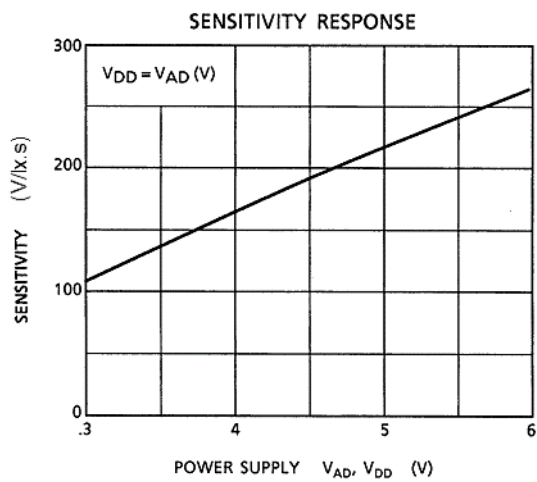
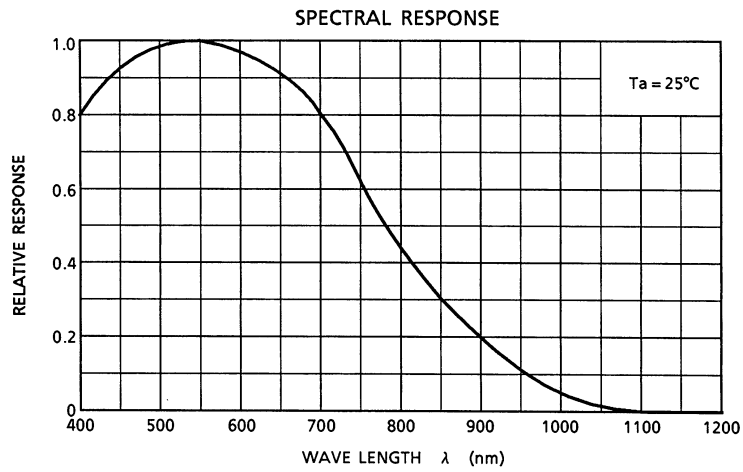

TYPICAL PERFORMANCE CURVES

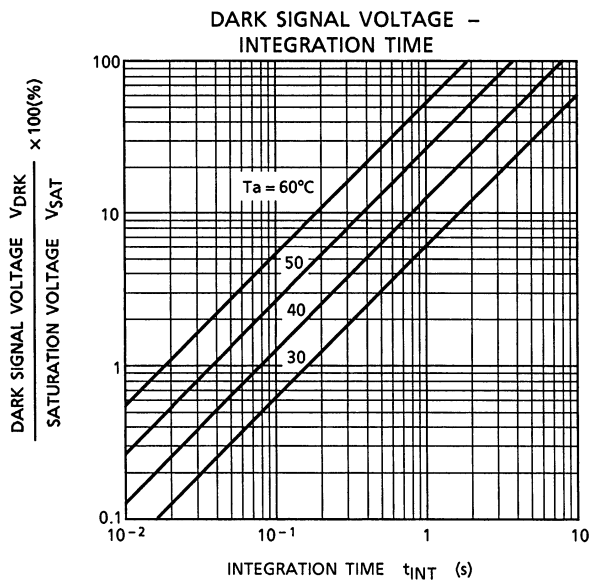
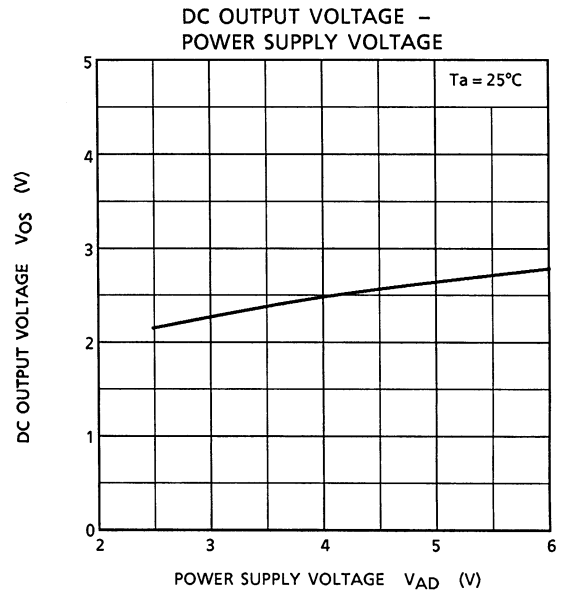
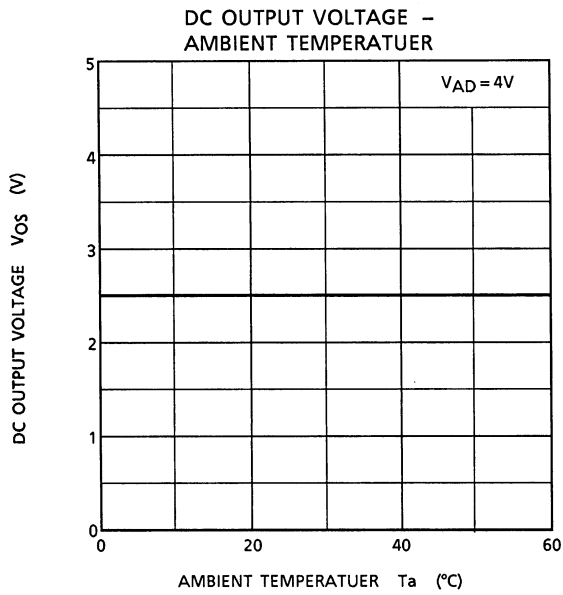

TYPICAL DRIVE CIRCUIT

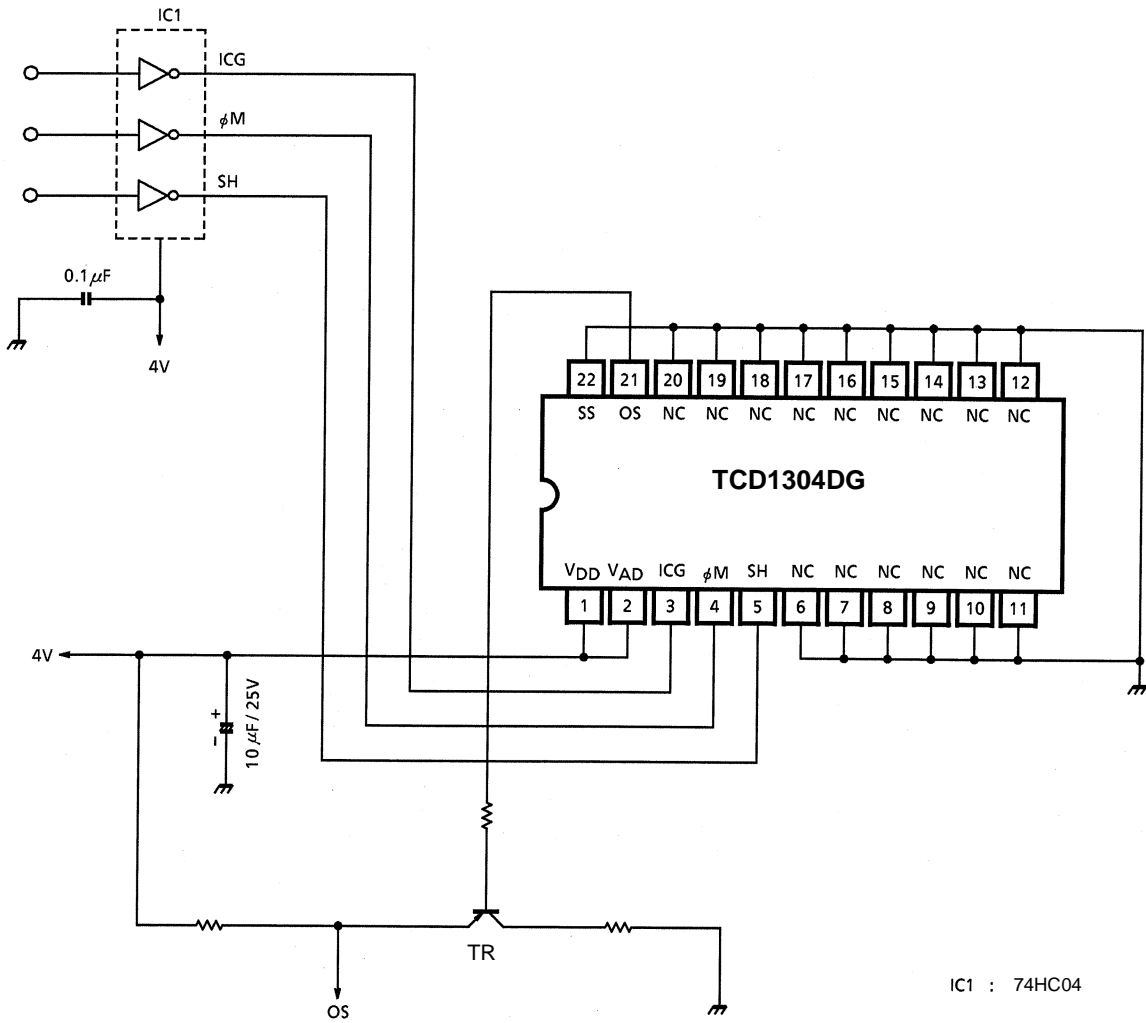

CAUTION**1. Window Glass**

The dust and stain on the glass window of the package degrade optical performance of CCD sensor.

Keep the glass window clean by saturating a cotton swab in alcohol and lightly wiping the surface, and allow the glass to dry, by blowing with filtered dry N₂. Care should be taken to avoid mechanical or thermal shock because the glass window is easily to damage.

2. Electrostatic Breakdown

Store in shorting clip or in conductive foam to avoid electrostatic breakdown.

CCD Image Sensor is protected against static electricity, but interior puncture mode device due to static electricity is sometimes detected. In handing the device, it is necessary to execute the following static electricity preventive measures, in order to prevent the trouble rate increase of the manufacturing system due to static electricity.

- a. Prevent the generation of static electricity due to friction by making the work with bare hands or by putting on cotton gloves and non-charging working clothes.
- b. Discharge the static electricity by providing earth plate or earth wire on the floor, door or stand of the work room.
- c. Ground the tools such as soldering iron, radio cutting pliers or pincer.

It is not necessarily required to execute all precaution items for static electricity.

It is all right to mitigate the precautions by confirming that the trouble rate within the prescribed range.

3. Incident Light

CCD sensor is sensitive to infrared light. Note that infrared light component degrades resolution and PRNU of CCD sensor.

4. Lead Frame Forming

Since this package is not strong against mechanical stress, you should not reform the lead frame.

We recommend to use a IC-inserter when you assemble to PCB.

5. Soldering

Soldering by the solder flow method cannot be guaranteed because this method may have deleterious effects on prevention of window glass soiling and heat resistance.

Using a soldering iron, complete soldering within 10 seconds for lead temperatures of up to 260°C, or within 3 seconds for lead temperatures of up to 350°C.

PACKAGE DIMENSIONS

WDIP22-G-400-2.54H

Unit : mm

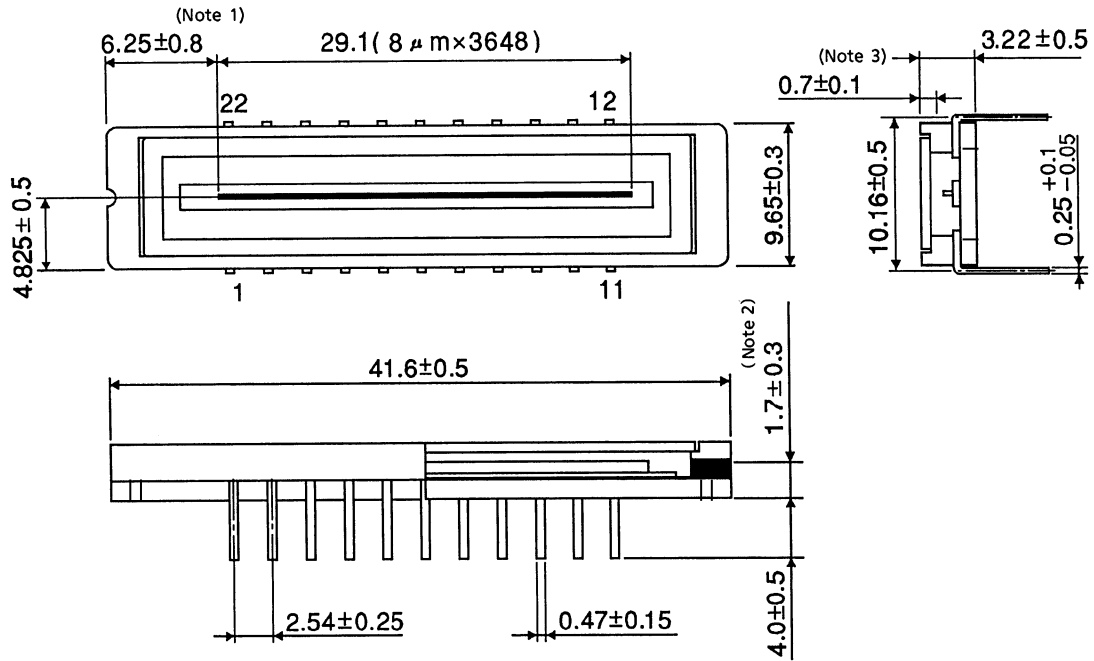

Note 1: No. 1 SENSOR ELEMENT (S1) TO EDGE OF PACKAGE.

Note 2: TOP OF CHIP TO BOTTOM OF PACKAGE.

Note 3: GLASS THICKNES (n = 1.5)

Weight: (3.5g (Typ.))

RESTRICTIONS ON PRODUCT USE

Toshiba Corporation and its subsidiaries and affiliates are collectively referred to as "TOSHIBA". Hardware, software and systems described in this document are collectively referred to as "Product".

- TOSHIBA reserves the right to make changes to the information in this document and related Product without notice.
- This document and any information herein may not be reproduced without prior written permission from TOSHIBA. Even with TOSHIBA's written permission, reproduction is permissible only if reproduction is without alteration/omission.
- Though TOSHIBA works continually to improve Product's quality and reliability, Product can malfunction or fail. Customers are responsible for complying with safety standards and for providing adequate designs and safeguards for their hardware, software and systems which minimize risk and avoid situations in which a malfunction or failure of Product could cause loss of human life, bodily injury or damage to property, including data loss or corruption. Before customers use the Product, create designs including the Product, or incorporate the Product into their own applications, customers must also refer to and comply with (a) the latest versions of all relevant TOSHIBA information, including without limitation, this document, the specifications, the data sheets and application notes for Product and the precautions and conditions set forth in the "TOSHIBA Semiconductor Reliability Handbook" and (b) the instructions for the application with which the Product will be used with or for. Customers are solely responsible for all aspects of their own product design or applications, including but not limited to (a) determining the appropriateness of the use of this Product in such design or applications; (b) evaluating and determining the applicability of any information contained in this document, or in charts, diagrams, programs, algorithms, sample application circuits, or any other referenced documents; and (c) validating all operating parameters for such designs and applications. **TOSHIBA ASSUMES NO LIABILITY FOR CUSTOMERS' PRODUCT DESIGN OR APPLICATIONS.**
- **PRODUCT IS NEITHER INTENDED NOR WARRANTED FOR USE IN EQUIPMENTS OR SYSTEMS THAT REQUIRE EXTRAORDINARILY HIGH LEVELS OF QUALITY AND/OR RELIABILITY, AND/OR A MALFUNCTION OR FAILURE OF WHICH MAY CAUSE LOSS OF HUMAN LIFE, BODILY INJURY, SERIOUS PROPERTY DAMAGE AND/OR SERIOUS PUBLIC IMPACT ("UNINTENDED USE").** Except for specific applications as expressly stated in this document, Unintended Use includes, without limitation, equipment used in nuclear facilities, equipment used in the aerospace industry, medical equipment, equipment used for automobiles, trains, ships and other transportation, traffic signaling equipment, equipment used to control combustions or explosions, safety devices, elevators and escalators, devices related to electric power, and equipment used in finance-related fields. **IF YOU USE PRODUCT FOR UNINTENDED USE, TOSHIBA ASSUMES NO LIABILITY FOR PRODUCT.** For details, please contact your TOSHIBA sales representative.
- Do not disassemble, analyze, reverse-engineer, alter, modify, translate or copy Product, whether in whole or in part.
- Product shall not be used for or incorporated into any products or systems whose manufacture, use, or sale is prohibited under any applicable laws or regulations.
- The information contained herein is presented only as guidance for Product use. No responsibility is assumed by TOSHIBA for any infringement of patents or any other intellectual property rights of third parties that may result from the use of Product. No license to any intellectual property right is granted by this document, whether express or implied, by estoppel or otherwise.
- **ABSENT A WRITTEN SIGNED AGREEMENT, EXCEPT AS PROVIDED IN THE RELEVANT TERMS AND CONDITIONS OF SALE FOR PRODUCT, AND TO THE MAXIMUM EXTENT ALLOWABLE BY LAW, TOSHIBA (1) ASSUMES NO LIABILITY WHATSOEVER, INCLUDING WITHOUT LIMITATION, INDIRECT, CONSEQUENTIAL, SPECIAL, OR INCIDENTAL DAMAGES OR LOSS, INCLUDING WITHOUT LIMITATION, LOSS OF PROFITS, LOSS OF OPPORTUNITIES, BUSINESS INTERRUPTION AND LOSS OF DATA, AND (2) DISCLAIMS ANY AND ALL EXPRESS OR IMPLIED WARRANTIES AND CONDITIONS RELATED TO SALE, USE OF PRODUCT, OR INFORMATION, INCLUDING WARRANTIES OR CONDITIONS OF MERCHANTABILITY, FITNESS FOR A PARTICULAR PURPOSE, ACCURACY OF INFORMATION, OR NONINFRINGEMENT.**
- Do not use or otherwise make available Product or related software or technology for any military purposes, including without limitation, for the design, development, use, stockpiling or manufacturing of nuclear, chemical, or biological weapons or missile technology products (mass destruction weapons). Product and related software and technology may be controlled under the applicable export laws and regulations including, without limitation, the Japanese Foreign Exchange and Foreign Trade Law and the U.S. Export Administration Regulations. Export and re-export of Product or related software or technology are strictly prohibited except in compliance with all applicable export laws and regulations.
- Please contact your TOSHIBA sales representative for details as to environmental matters such as the RoHS compatibility of Product. Please use Product in compliance with all applicable laws and regulations that regulate the inclusion or use of controlled substances, including without limitation, the EU RoHS Directive. **TOSHIBA ASSUMES NO LIABILITY FOR DAMAGES OR LOSSES OCCURRING AS A RESULT OF NONCOMPLIANCE WITH APPLICABLE LAWS AND REGULATIONS.**

TOSHIBA ELECTRONIC DEVICES & STORAGE CORPORATION