

DESCRIPTION

The MP3332 is a dual-channel, flash LED driver for high-resolution camera phones. It comes in a very compact package and is highly efficient at improving image and video quality in low-light environments. The synchronous boost converter operates at 1/2/3/4MHz to provide higher efficiency and an optimized solution for smaller PCB spaces.

The MP3332 features a standard I²C interface, dual LED channels, high-power density, and multiple protection features. The MP3332 supports flash, assist, torch, indicator, and 5V DC modes.

To improve thermal performance, the cathodes of the dual flash LED are referenced to GND for a better layout. It is available in a WLCSP-16 (1.7mmx1.7mm) package.

FEATURES

- 2.7V~5.5V Input Voltage
- Dual-Channel, 1.5A/Ch Flash Current with +/-7% Accuracy
- 1/2/3/4MHz Selectable Switching Frequency and Switching Frequency Foldback Function
- 400kHz I²C Compatible Interface
- Standby/Flash/Assist/Torch/Indicator/5V DC Modes

Flash Mode:

- Up to 1.5A/Ch Programmable Current with +/-7% Accuracy for Each LED

Assist/Torch Mode:

- Up to 500mA/Ch Programmable Current with +/-7% Accuracy for Each LED

Indicator Mode:

- Works in 31.5kHz PWM Operation with 2/16, 3/16, 4/16, 5/16 Duty Cycle
- 128ms/256ms/512ms Selectable Blinking Time

5V DC Mode:

- Constant 5V DC Output
- External Torch/Strobe
- LED Forward-Voltage Balance to Improve Efficiency
- 1A to 4.2A Programmable Input DC Current-Limit Protection
- Low-Battery Voltage Protection
- LED Short/Open Protection
- VOUT-GND Short Protection
- Over-Voltage Protection (OVP)
- Over-Temperature Protection (OTP)
- NTC Detection and Protection
- Input Under-Voltage Lockout (UVLO) Protection
- Available in a WLCSP-16 (1.7mmx1.7mm) Package

APPLICATIONS

- LED Flash for Smart Phones
- Cameras for Tablet
- Digital Still Camera

All MPS parts are lead-free, halogen-free, and adhere to the RoHS directive. For MPS green status, please visit the MPS website under Quality Assurance. "MPS" and "The Future of Analog IC Technology" are registered trademarks of Monolithic Power Systems, Inc.

TYPICAL APPLICATION

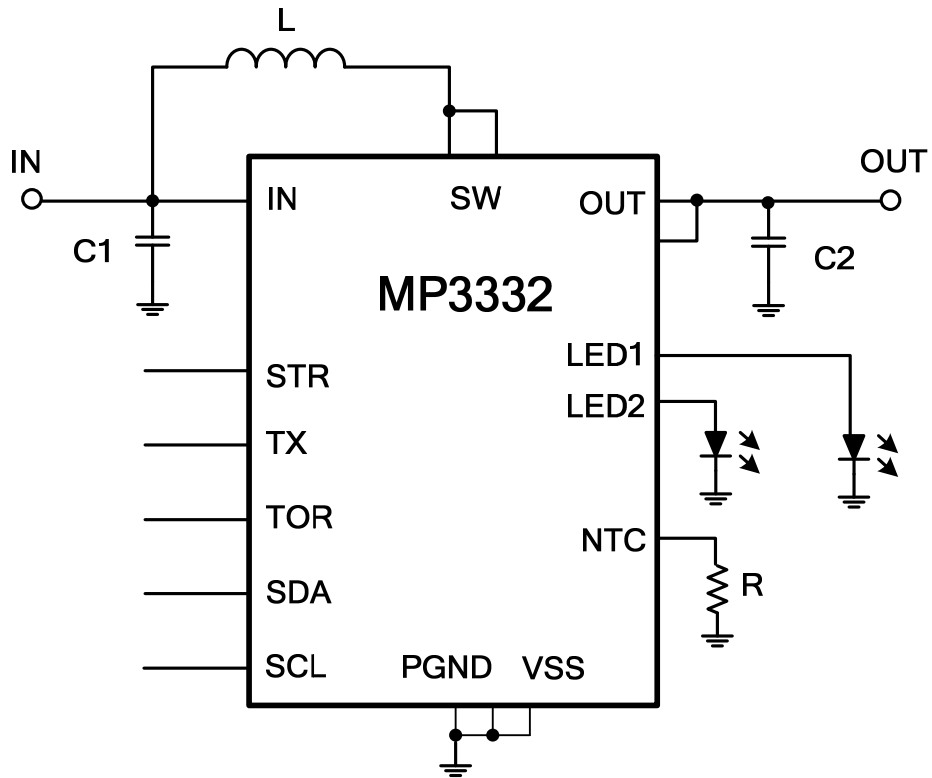

ORDERING INFORMATION

Part Number*	Package	Top Marking
MP3332GC	WLCSP-16 (1.7mmx1.7mm)	See Below

* For Tape & Reel, add suffix -Z (e.g. MP3332GC-Z)

TOP MARKING

—
DFY
LLL

DFY: Product code of MP3332GC
 LLL: Lot number

PACKAGE REFERENCE

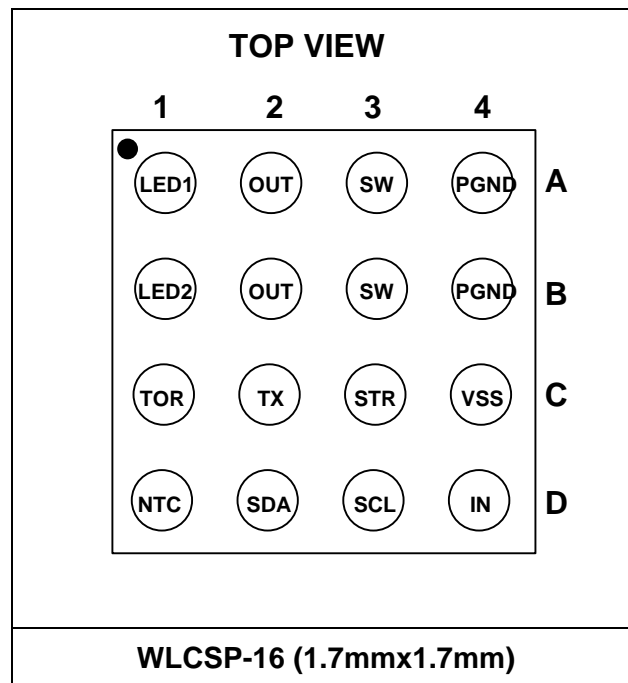

ABSOLUTE MAXIMUM RATINGS ⁽¹⁾

V_{IN}, V_{SW}, V_{OUT}	-0.3V to +6V
NTC	-0.3V to $V_{IN} + 0.3V$
All other pins	-0.3V to +6V
Junction temperature	150°C
Lead temperature	260°C
Continuous power dissipation ($T_A = 25^\circ C$) ⁽²⁾	
.....	1.47W

Recommended Operating Conditions ⁽³⁾

Supply voltage (V_{IN})	2.7V to 5.5V
Operating junction temp. (T_J) ..	-40°C to +125°C

Thermal Resistance ⁽⁴⁾	θ_{JA}	θ_{JC}	
WLCSP-16 (1.7mmx1.7mm) ...	85	0.5	°C/W

NOTES:

- 1) Exceeding these ratings may damage the device.
- 2) The maximum allowable power dissipation is a function of the maximum junction temperature T_J (MAX), the junction-to-ambient thermal resistance θ_{JA} , and the ambient temperature T_A . The maximum allowable continuous power dissipation at any ambient temperature is calculated by P_D (MAX) = $(T_J$ (MAX) - T_A) / θ_{JA} . Exceeding the maximum allowable power dissipation produces an excessive die temperature, causing the regulator to go into thermal shutdown. Internal thermal shutdown circuitry protects the device from permanent damage.
- 3) The device is not guaranteed to function outside of its operating conditions.
- 4) Measured on JESD51-7, 4-layer PCB.

ELECTRICAL CHARACTERISTICS

V_{IN} = 3.6V, T_A = 25°C, unless otherwise noted.

Parameters	Symbol	Condition	Min	Typ	Max	Units
Supply						
Operating input voltage	V _{IN}		2.7		5.5	V
Input UVLO threshold	V _{IN_UVLO}	Rising edge		2.5		V
Input UVLO hysteresis				100		mV
Standby current	I _{Q_STANDBY}	V _{IN} = 2.7V to 5.5V, I ² C active			15	μA
Operating quiescent current	I _Q	V _{IN} = 3.6V, no switching, pass mode		1		mA
Switching Regulator						
Switching frequency	f _s	SW_FS = 11	0.9	1	1.1	MHz
Minimum on time	t _{ON_MIN}			68		ns
NMOS on resistance	R _{DSON_N}	V _{IN} = 3.6V		65		mΩ
PMOS on resistance	R _{DSON_P}	V _{IN} = 3.6V		80		mΩ
Constant DC output voltage	V _{OUT_5V}	5V DC mode		5		V
Inductor current limit ⁽⁵⁾	I _{LIMIT}	Code setting = 10, max duty cycle		3.5		A
LED Driver						
Flash current setting	I _{LED_FLASH}	Flash mode, value setting = 00000000		0		mA
		Flash mode, value setting = 00110011	279	300	321	mA
Torch current setting	I _{LED_TORCH}	Assist light/torch mode, value setting = 00000000		0		mA
		Assist light /torch mode, value setting = 00110011	279	300	321	mA
Current source headroom voltage	V _{HD}	Current = 1250mA ⁽⁵⁾		350		mV
		Current = 200mA		190		mV
Current ramp-up step time ⁽⁵⁾	t _{RAMP_UP}	TUP_I = 111		1		μs
		TUP_I = 000		8		μs
Current ramp-down step time ⁽⁵⁾	t _{RAMP_DOWN}			1		μs
LED1/2 load balance voltage hysteresis	V _{LED_HYS}			125		mV
Digital Input						
Input logic low voltage					0.4	V
Input logic high voltage			1.2			V
STR/TOR/TX pull-down resistor				250		kΩ

NOTE:

5) Guaranteed by design.

ELECTRICAL CHARACTERISTICS (continued)
V_{IN} = 3.6V, T_A = 25°C, unless otherwise noted.

Parameters	Symbol	Condition	Min	Typ	Max	Units
Protection						
Time-out time	t _{TIMEOUT}	Time setting code = 0011	190	200	210	ms
Input DC current limit ⁽⁵⁾	I _{LIMIT_IN}	Current setting code = 0010 boost mode		1.5		A
Over-voltage threshold	V _{OVP}		5.335	5.5	5.665	V
LED1/2 short detection voltage	V _{LED_ST}			1		V
PMOS charge current		V _{OUT} < 2.3V		230		mA
LED1/2 open detection voltage	V _{LED_OP}			100		mV
Thermal shutdown threshold	T _{LSD}			150		°C
Adaptive thermal threshold				130		°C
NTC detection voltage	V _{NTC}	Code setting = 001		0.6		V
		Code setting = 111		1.02		V
Low battery threshold	V _{BAT_LOW}	Code setting = 000		3		V
		Code setting = 110		3.6		V
I²C Interface						
Input logic low	V _{IL}				0.4	V
Input logic high	V _{IH}		1.3			V
Output logic low	V _{OL}	I _{LOAD} = 3mA			0.4	V
SCL clock frequency	F _{SCL}				400	kHz
SCL high time	t _{HIGH}		0.6			μs
SCL low time	t _{LOW}		1.3			μs
Data setup time	t _{SU,DAT}		100			ns
Data hold time	t _{HD,DAT}		0		0.9	μs
Setup time for repeated start	t _{SU,STA}		0.6			μs
Hold time for start	t _{HD,STA}		0.6			μs
Bus free time between a start and stop condition	t _{BUF}		1.3			μs
Setup time for stop condition	t _{SU,STO}		0.6			μs
Rise time of SCL and SDA	t _R		20+0.1 *C _B		300	ns
Fall time of SCL and SDA	t _F		20+0.1 *C _B		300	ns
Pulse width of suppressed spike	t _{SP}		0		50	ns
Capacitance bus for each bus line	C _B				400	pF

NOTE:

5) Guaranteed by design.

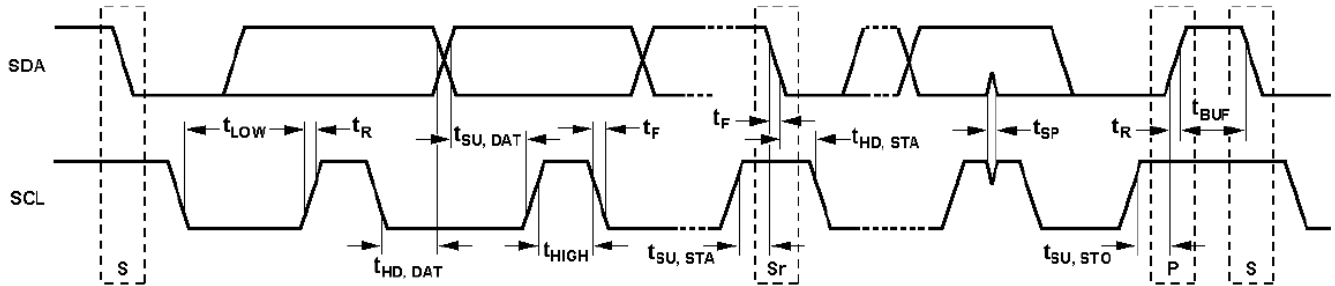

S = START CONDITION
 Sr = REPEATED START CONDITION
 P = STOP CONDITION

I²C Compatible Interface Timing Diagram

TYPICAL PERFORMANCE CHARACTERISTICS

V_{IN} = 3.6V, 2-Channel, L = 1.2μH, T_A = 25°C, unless otherwise noted.

Torch/Assist Mode

LED_EN enable

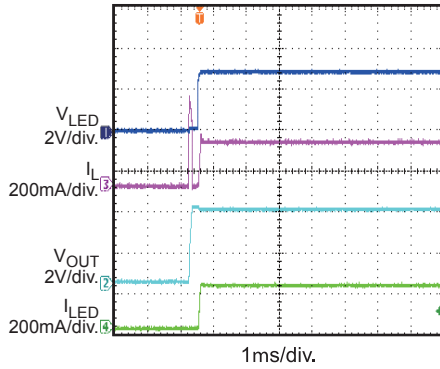

Torch/Assist Mode

LED_EN disable

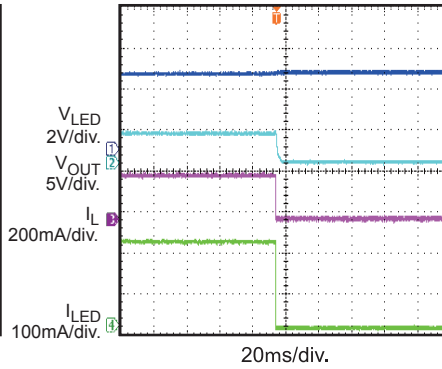

Indicator Mode

I_{LED} Duty=2/16

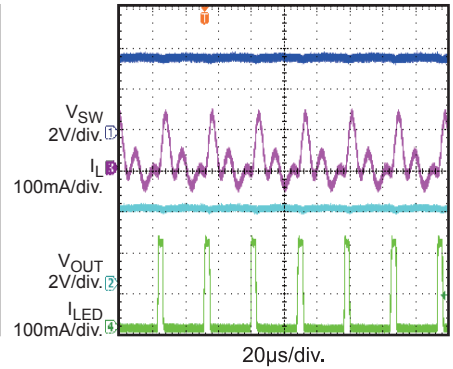

Blinking Mode and Indicator Mode

Blinking Time=128ms

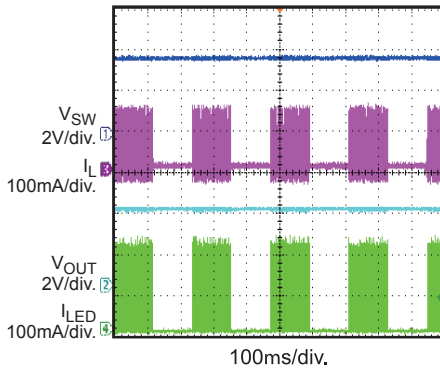

Flash Mode

flash time=100ms

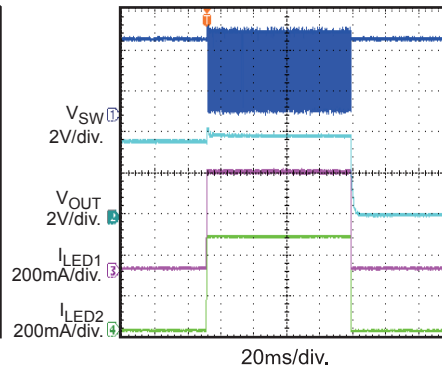

5V_DC Mode

With light load

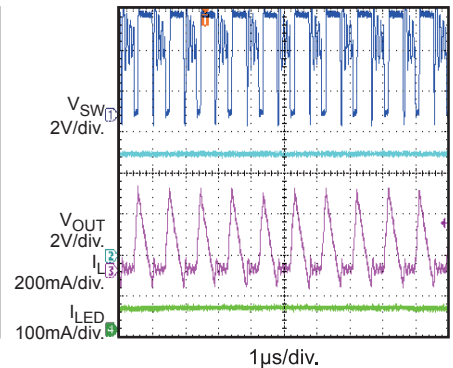

Torch/Assist Mode to Flash Mode

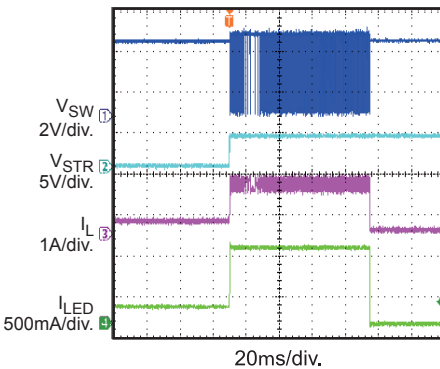

TX Pin is High in Flash Mode

in Flash Mode

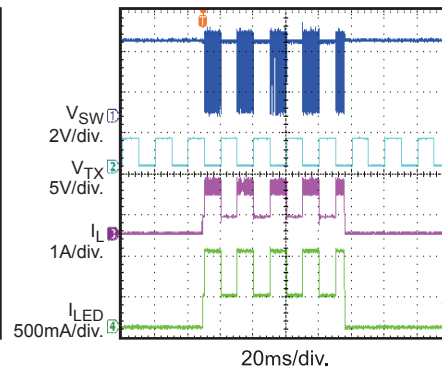

Load Balancing

from disable this function to enable

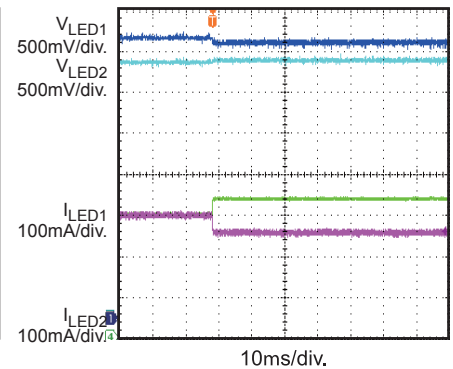

TYPICAL PERFORMANCE CHARACTERISTICS (continued)

V_{IN} = 3.6V, 2-Channel, L = 1.2μH, T_A = 25°C, unless otherwise noted.

Short One Channel
when working

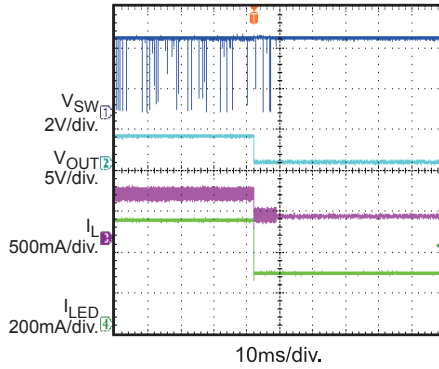

Open One-String Protection
when working

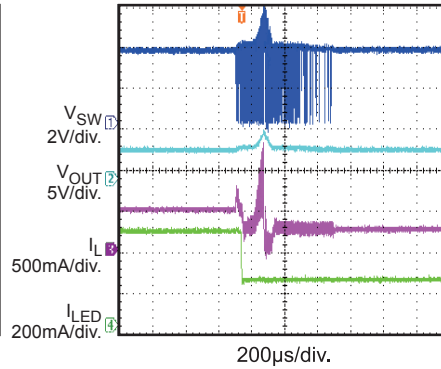

Vout to GND Short Protection

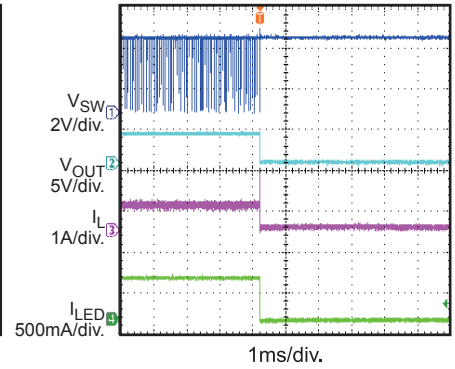

Thermal Protection
In flash mode
Set LED_OTAD to 1

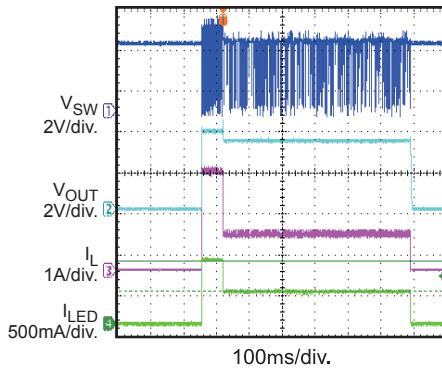

NTC Detection
Set NTC_WD=0.88V

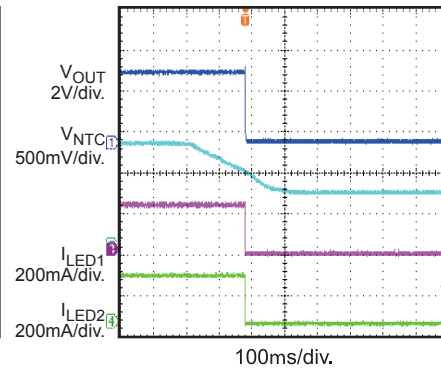

PIN FUNCTIONS

Pin #	Name	Description
A1	LED1	Current source for LED1. Connect the anode of an LED to LED1.
A2/B2	OUT	Boost converter output.
A3/B3	SW	Boost converter switching node.
A4/B4	PGND	Power GND.
B1	LED2	Current source for LED2. Connect the anode of an LED to LED2.
C1	TOR	Torch mode input signal.
C2	TX	Synchronization input signal for RF transmission signal. Pull TX low internally to float.
C3	STR	Strobe signal input. STR synchronizes the flash pulse. Pull STR low internally to float.
C4	VSS	Analog GND.
D1	NTC	LED temperature detection. Connect NTC to GND with an NTC resistor when the NTC function is used. Float NTC when not in use.
D2	SDA	I²C interface data input.
D3	SCL	I²C interface clock input.
D4	IN	Input supply. IN provides the power for the internal power and logic circuit. Bypass IN locally.

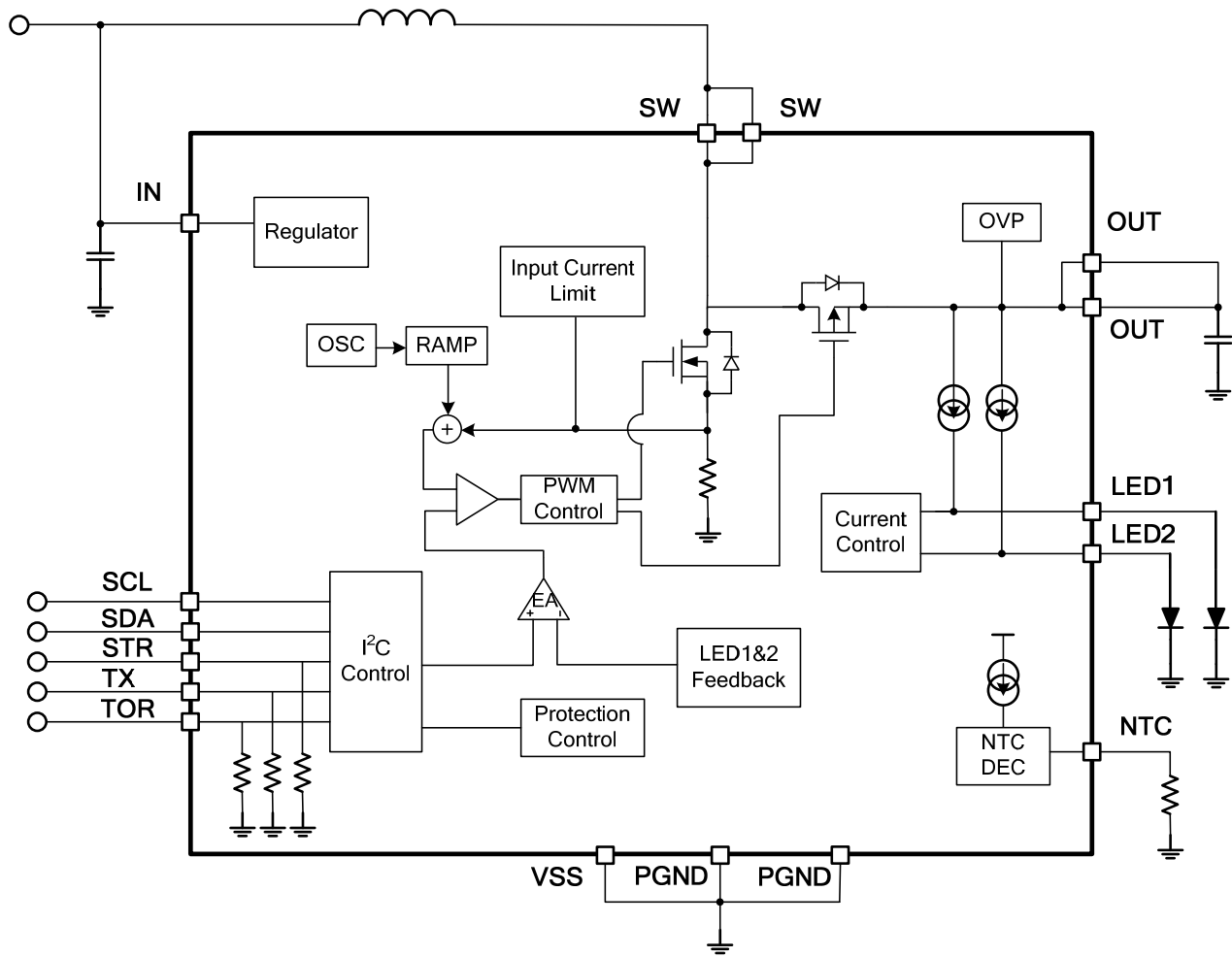

Figure 1: Functional Block Diagram

OPERATION

The MP3332 is a dual-channel, flash LED driver with an I²C interface for phone and tablet cameras. It works in standby mode, flash mode, assist mode, torch mode, indicator mode, and fixed 5V DC output mode.

Table 1 shows how to set the operation mode and flash trigger mode when the STR_POL bit is set to 1. If STR_POL is set to 0, STR switches to low.

LED Driver Operation

The MP3332 uses PWM mode with peak current control to regulate the LED current. It

works in a selectable 1M/2M/3M/4MHz switching frequency with a synchronous rectifier PMOS. When enabled, the synchronous PMOS works as a 230mA current source to charge the output capacitor until V_{OUT} rises to 2.3V. If the voltage across the current source (V_{OUT}-V_{LED}) is less than the target reference (set by VTH_PAS1/2 bits, 05H register), the IC works in boost switching mode; otherwise, it works in pass mode. In pass mode, the synchronous PMOS is turned on completely. During the current start-up, the current ramps up step-by-step to the target current.

Table 1: Operation Mode Setting and Flash Trigger Mode

Configuration							Mode
TX Pin	TOR Pin	STR	STR_MOD	LED1/2_EN	5V_MOD	LED_MOD	
X	High	Float	X	1	X	00	Torch
		High	1				Torch to flash
X	X	Float	X	1	X	10	Assist light
		High	1				Assist to flash
X	X	X	X	1	X	01	Indicator
0	X	High	1	1	X	11	Flash
1	X	High	1	1	X	11	Flash
X	X	X	0	1	X	11	Flash
X	X	X	X	X	1	X	5V

Standby Mode

In default, if V_{IN} is higher than UVLO, the device switches to standby mode; the I²C is active and is ready to communicate with the host.

Torch Mode

If TOR goes high in standby mode, the device switches to torch mode, and the current ramps up step-by-step after setting LED1/2_EN to 1. The LED1 and LED2 currents can be set by registers I1_TOR and I2_TOR respectively. The ramp-up slew rate can be set by register TUP_I. The current can be disabled by pulling TOR low or by setting LED1/2_EN to 0. LED1_EN and LED2_EN control LED1 and LED2's current sources respectively. After pulling TOR low, the LED1/2_EN and LED_MOD bits are reset to the default value automatically if LED_SD is 0. If LED_SD is 1, LED1/2_EN does not reset (see Figure 2).

MP3332 Torch Mode:

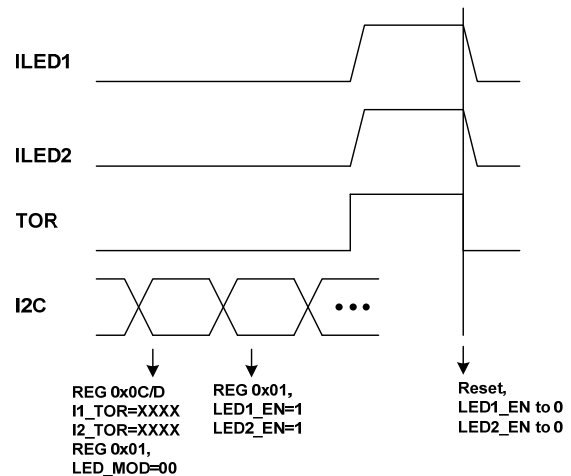

Figure 2: Torch Mode

Assist Mode

The device enters assist mode by setting LED_MOD to 10 and the LED1/2_EN bits to 1 (see Figure 3). The LED1 and LED2 current sources are controlled by the LED1_EN and LED2_EN bits respectively. The ramp-up slew rate can be set by register TUP_I. The currents can be disabled by switching to standby mode or by setting the LED1_EN and LED2_EN bits to 0.

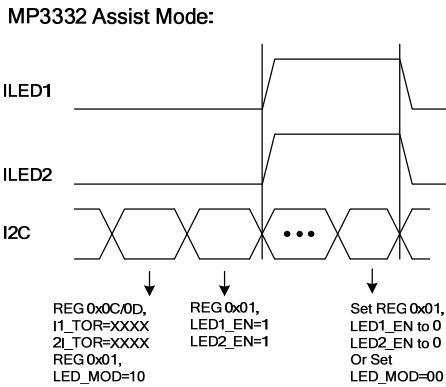

Figure 3: Assist Mode

Indicator Mode

The device enters indicator mode for a lower current output when LED_MOD is set to 01, and LED1/2 is set to 1 (see Figure 4). In indicator mode, the driver outputs a current in 31.5kHz PWM dimming mode. The current amplitude is set by I1_TOR and I2_TOR, and the duty cycle is set by the INDI_PWM register. Set the LED1/2_EN bits to 0, or switch to standby mode to disable indicator mode. The LED1 and LED2 current sources are controlled by the LED1_EN and LED2_EN bits respectively.

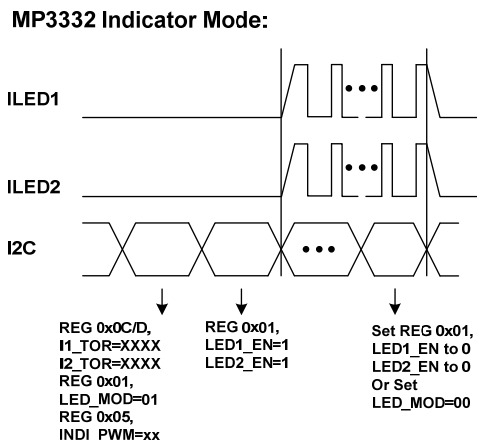

Figure 4: Indicator Mode

If blinking function is enabled, LED1/2 turn on for the blinking time and then turn off for the same blinking time period. The cycle repeats continuously in indicator mode (see Figure 5). The blinking time is set by the TBK0/1 bits in register 0FH.

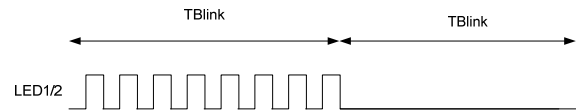

Figure 5: Blinking Function

Flash Mode

The device can work in flash mode in the following ways:

1. Hardware and Level Trigger Mode

In this mode, STR_MOD = 1, STR_LV = 1, LED1/2_EN = 1, and LED_MOD = 11. The flash current starts ramping up after STR goes high. The currents are set by I_FL_1 and I_FL_2, and the ramp-up time is set by TUP_I. The flash current ends when STR is pulled low. After the flash, LED_MOD is reset to standby mode, and LED1/2_EN is reset to 0 if LED_SD = 0. If LED_SD = 1, LED_MOD and LED1/2_EN are not reset. The LED1 and LED2 current sources are controlled by the LED1_EN and LED2_EN bits respectively. If the flash timer set by the register bit FL_TIM ends before STR goes low, the flash current terminates immediately. LED_MOD and LED1/2_EN are reset to the default value if LED_SD is 0 and the time-out fault bit FT_TO is set to 1 and is not cleared until it is read back, or the input power is reset (see Figure 6 and Figure 7).

MP3332 Hardware and Level Sensitive Flash Mode w/o Timer-Out:

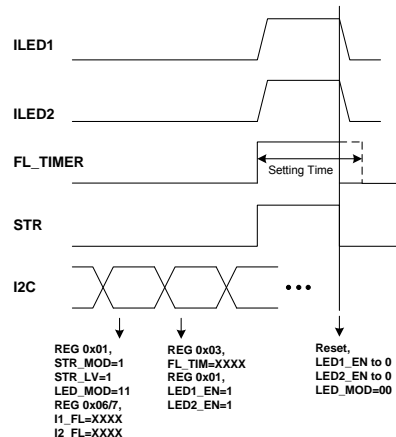

Figure 6: Hardware and Level Trigger Flash Mode without Timer-Out

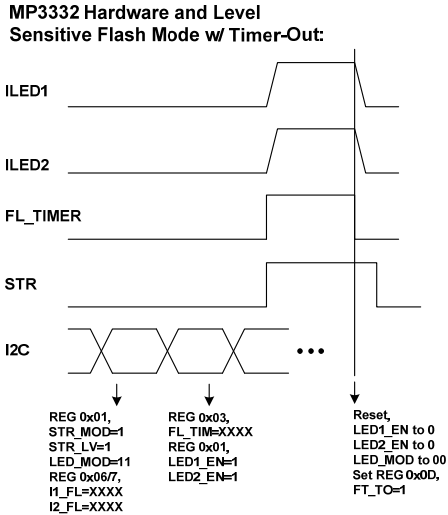

Figure 7: Hardware and Level Trigger Flash Mode with Timer-Out

2. Hardware and Edge Trigger Mode

In this mode, STR_MOD = 1, STR_LV = 0, LED1/2_EN = 1, and LED_MOD = 11 (see Figure 8). The flash current begins ramping up after STR goes high. The LED1 and LED2 currents are set by I_FL_1 and I_FL_2 respectively, and the ramp-up time is set by TUP_I. The flash current ends when the flash timer set by FL_TIM ends. After the flash, the LED_MOD is reset to standby mode, and LED1/2_EN is reset to 0 if LED_SD = 0. If LED_SD = 1, the mode, LED_MOD, and LED1/2_EN are not reset. The LED1 and LED2 current sources are controlled by the LED1_EN and LED2_EN bits respectively.

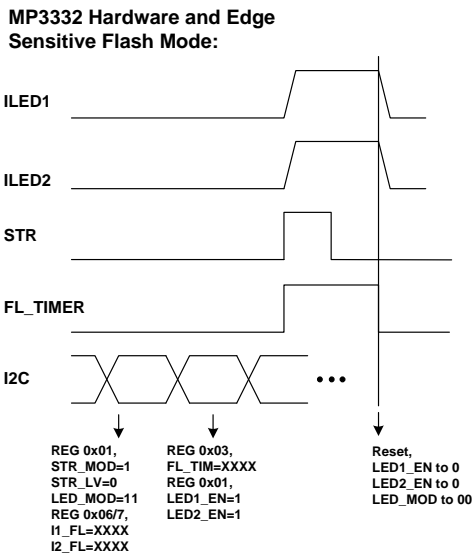

Figure 8: Hardware and Edge Trigger Flash Mode

3. Software and Edge Trigger Mode

In this mode, STR_MOD = 0, LED1/2_EN = 1, and LED_MOD = 11 (see Figure 9). The LED1 and LED2 currents are set by I_FL_1 and I_FL_2 respectively, and the ramp-up time is set by TUP_I. The flash current ends when the flash timer set by FL_TIM ends. After the flash, LED_MOD is reset to standby mode, and LED1/2_EN is reset to 0 if LED_SD = 0. If LED_SD = 1, LED_MOD and LED1/2_EN are not reset. The LED1 and LED2 current sources are controlled by the LED1_EN and LED2_EN bits respectively.

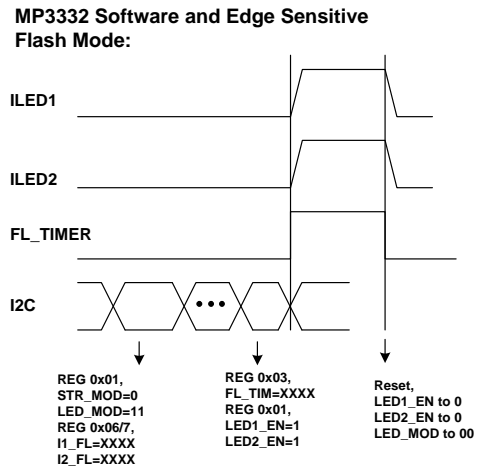

Figure 9: Software and Edge Trigger Flash Mode Torch Mode to Flash Mode

The MP3332 can switch to flash mode from torch mode directly when STR goes high if STR_MOD=1 (see Figure 10). After the flash, the part operates in flash mode.

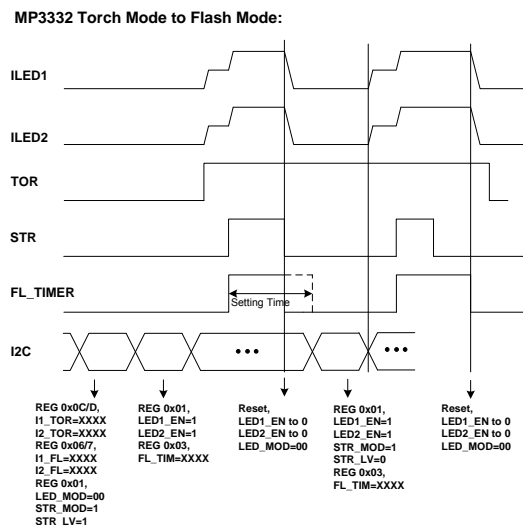

Figure 10: Torch Mode to Flash Mode

Assist Mode to Flash Mode

During assist light mode, the device can switch to flash mode from assist light mode directly when STR goes high if STR_MOD = 1 (see Figure 11). After the flash, the part operates in flash mode.

MP3332 Assist Light Mode to Flash Mode:

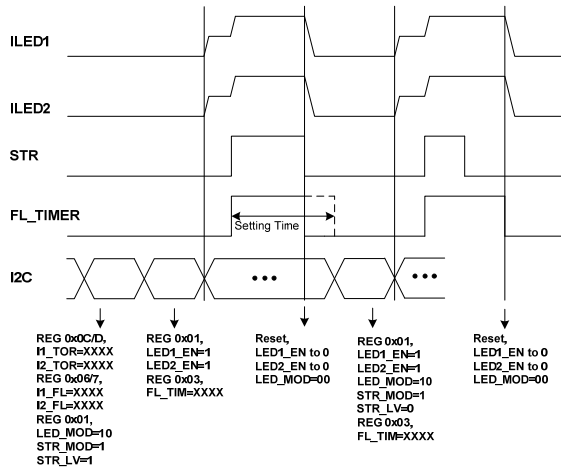

Figure 11: Assist Mode to Flash Mode

5V DC Output Mode

If 5V_MOD is set to 1, the device works in fixed 5V output mode, and the control loop is taken over by the voltage loop (see Figure 12). Note that the LED current source can still output a current if the mode conditions described above are met. Since the 5V DC directly powers the LED, care must be taken to ensure thermal conditions are normal. It is recommended to set the LED1/2_EN bit to 0 during 5V mode.

MP3332 5V DC Mode:

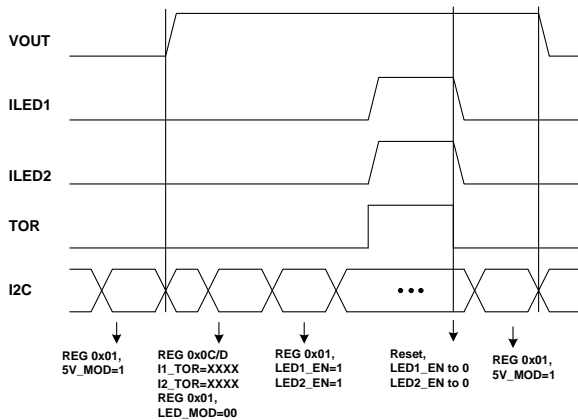

Figure 12: 5V DC Output Mode

Switching Frequency Setting

The maximum switching frequency can be selected by the SW_FS bits when operating in boost mode. 1M/2M/3M/4MHz can be selected to optimize efficiency.

Switching Frequency Foldback

In 4/3/2MHz switching mode, if the voltage across the current source is larger than the value set by the register bit VTH_PAS, the IC switches to 1MHz to improve efficiency and EMI. When FS_SD = 0, if the voltage across the current source is still larger than the value set by the register bits VTH_PAS in 1MHz mode, the switching frequency can be stretched down to 100kHz. If the input voltage continues rising or the load becomes lighter, the IC switches to pass mode from 100kHz. When FS_SD = 1, the IC switches directly to pass mode from 1MHz.

Load Balancing

To improve efficiency, the device provides a load balancing function to reduce unbalanced forward voltage drops between dual LEDs (see Figure 13). To enable this function, set the bit BAL_ON to 1. If $V_{LED1} > V_{LED2} + V_{LED_HYS}$, the LED1 current drops step-by-step while the LED2 current rises step-by-step, and $|V_{LED1} - V_{LED2}| < V_{LED_HYS}$ or $I_{LED1} < 90\% I_{LED2}$.

The maximum adjustment range of each LED current is limited to 10%. Because of the limitation, if there is a large difference between V_{LED1} and V_{LED2} , the load balance function cannot ensure $|V_{LED1} - V_{LED2}| < V_{LED_HYS}$. It is recommended to further reduce the voltage difference. If $V_{LED2} > V_{LED1} + V_{LED_HYS}$, the operation is the same.

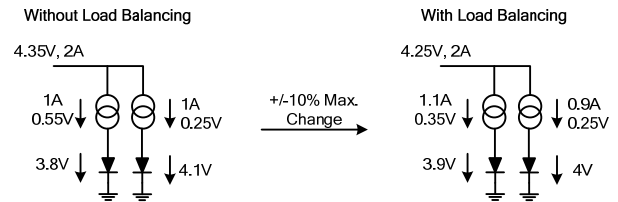

Figure 13: Load Balancing

Current Reduction

When the MP3332 works in flash mode, the output current may drop due to the following conditions:

1. TX is High

TX is used to synchronize the RF transmission signal (see Figure 14). If TX goes high during flash mode, the flash current drops to the current set by I_TX in less than 5μs and sets the FT_TX bit to 1. If TX goes low, the current ramps up to the flash current again.

MP3332 Software and Edge Sensitive Flash Mode w/ TX is Active:

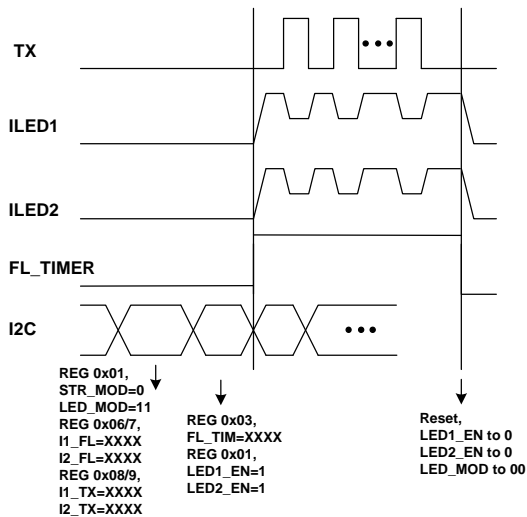

Figure 14: TX High

2. Input DC Current Limit is Triggered

The MP3332 uses the input DC current limit protection to avoid drawing excessive current from the battery. Since the input current limit is sensed in the NMOS switch, it is effective only in boost mode. This current can be programmed by the IL_DC register from 1A to 4.2A. If the input current hits the input current limit threshold, the LED output current holds until the input current limit drops below the current limit threshold. The fault bit FT_IDC is set to 1 if the input current limit is triggered. The fault bit remains until it is read back, or the input power is reset.

3. Low Battery Voltage Threshold is Triggered

The device provides low battery voltage protection in flash mode in the following ways:

1. Before the flash, if VBL_SD = 1 and the input voltage is lower than the threshold set by VBL_RUN, the device remains disabled and sets the fault bit FT_VBATL to 1 (see Figure 15). Conversely, if VBL_SD = 0, the device ramps up to the current set by I_TX and sets the fault bit FT_VBATL to 1. The fault bit is cleared after it is read back or the input power is reset.
2. During the flash pulse, if the battery voltage drops below the threshold set by VBL_RUN, the current reduces step-by-step until the battery voltage reaches the low battery voltage threshold. The minimum current caused by current reduction in the IFL_MIN register can be read back after the flash. The IFL_MIN value holds until the next flash occurs, or the power resets. At this condition, IFL_MIN can be read and used by system to set the flash current to ensure a stable flash current for next flash operation, which is MP3332 pre-flash function at low battery voltage.

MP3332 Software and Edge Sensitive Flash Mode w/ TX is Active:

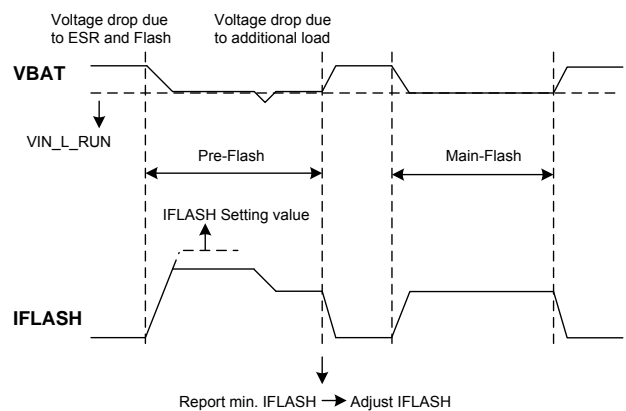

Figure 15: Pre-Flash Operation

NTC Detection

If the register NTC_WD is set to enable NTC detection, the NTC sources a constant 35µA current. Connect the negative temperature coefficient (NTC) resistor between NTC and GND (see Figure 16). If the voltage across the NTC resistor ($35\mu\text{A} \cdot R_{\text{NTC}}$) drops below the threshold set by NTC_WD, the internal fault bit FT_LEDHOT is set to 1, and the modes are reset to standby mode if LEDT_SD = 1. If LEDT_SD = 0, the mode setting is not reset after the fault bit is set. The fault bit remains until it is read back, or the power is reset. Float NTC when the protection mode is not needed.

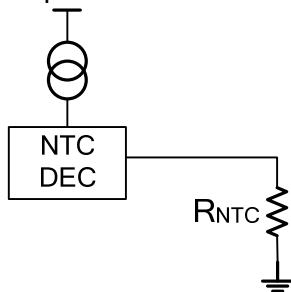

Figure 16: NTC Detection

VOUT-GND Short Protection

If $V_{\text{OUT}} < 1\text{V}$, the device stops switching and disconnects the synchronous PMOS to avoid drawing excessive current from the battery. Set the FT_VOOSC bit to 1 and reset the mode setting. The fault bit remains until it is read back, or the power is reset.

LED1/2-GND Short Protection

If $V_{\text{LED1}} < 1\text{V}$ and $I_{\text{LED1}} > 5\text{mA}$, or $V_{\text{LED2}} < 1\text{V}$ and $I_{\text{LED2}} > 5\text{mA}$, the IC marks off the current source and sets the fault bit FT_LEDSC to 1, but continues switching. If both current sources are marked off, the device stops switching, and the mode setting is reset. The fault bit FT_LEDSC is 1 until it is read back, or the power is reset. If LED_EN1/2 is set to 0, the feedback of the current source 1/2 is not involved in the loop control, and the fault detection on this channel is disabled.

LED1/2 Open Protection

If $V_{\text{OUT}} - V_{\text{LED1/2}} < 100\text{mV}$ and $V_{\text{OUT}} > 5.5\text{V}$, the fault current source is marked off, and the fault bit FT_OVP is set to 1, but continues switching. If both current sources are marked off, the device stops switching, and the mode setting is reset. The fault bit FT_OVP is 1 until it is read back, or the power is reset. If LED_EN1/2 is set to 0, the feedback of the current source 1/2 is not involved in the loop control, and the fault detection on this channel is disabled.

Output Over-Voltage Protection (OVP)

If $V_{\text{OUT}} > 5.5\text{V}$, the device stops switching and resumes normal operation when V_{OUT} drops below 5.2V. The fault bit FT_OVP is 1 until it is read back, or the power is reset.

Junction Over-Temperature Protection (OTP)

If $T_j > 130^\circ\text{C}$, the flash current drops to the current set by I_TX if LED_OTAD = 1, and the fault bit FT_OTP is set. If $T_j > 1^\circ\text{C}$, the device stops switching and resets the mode setting. The fault bit FT_OTP must be cleared to 0 by a read-back or power reset before restarting.

Time-Out Protection

If the device works in flash mode with hardware and level trigger enabled, the time-out protection is triggered when the STR pulse is longer than the time set by FL_TIM. The device stops switching and resets the mode setting bits when LED_SD = 0, and the fault bit FT_TO is 1 until it is read back, or the power is reset.

Under-Voltage Lockout (UVLO) Protection

If V_{IN} drops below the UVLO threshold, the device stops and all of the registers are reset to default.

I²C Interface Register Description

I²C Chip Address

After the start condition, the I²C compatible master sends a seven-bit address followed by an eighth read (Read: 1) or write (Write: 0) bit. The following bit indicates the register address to or from which the data is read or written.

0	1	1	0	1	1	1	R/W
---	---	---	---	---	---	---	-----

Register Map

Addr	REG	D7	D6	D5	D4	D3	D2	D1	D0
00H	Chip ID	DEV_ID4	DEV_ID3	DEV_ID2	DEV_ID1	DEV_ID0	REV_ID2	REV_ID1	REV_ID0
01H	Mode	STR_LV	STR_MOD	STR_POL	LED1_EN	LED2_EN	LED_MOD1	LED_MOD0	5V_MOD
02H	Peak Current	NTC_WD2	NTC_WD1	NTC_WD0	IL_PEAK1	IL_PEAK0	FS_SD	BAL_ON	NA
03H	Flash Timer	FL_TIM3	FL_TIM2	FL_TIM1	FL_TIM0	LED_SD	LEDT_SD	SW_FS1	SW_FS0
04H	Low Battery Voltage	VBL_RUN2	VBL_RUN1	VBL_RUN0	VBL_SD	IL_DC3	IL_DC2	IL_DC1	IL_DC0
05H	Indicator	LED_OTA D	TUP_I2	TUP_I1	TUP_I0	VTH_PAS 1	VTH_PAS2	INDI_PWM1	INDI_PWM0
06H	LED1 Flash Current	I1_FL7	I1_FL6	I1_FL5	I1_FL4	I1_FL3	I1_FL2	I1_FL1	I1_FL0
07H	LED2 Flash Current	I2_FL7	I2_FL6	I2_FL5	I2_FL4	I2_FL3	I2_FL2	I2_FL1	I2_FL0
08H	TX1 Current	I1_TX7	I1_TX6	I1_TX5	I1_TX4	I1_TX3	I1_TX2	I1_TX1	I1_TX0
09H	TX2 Current	I2_TX7	I2_TX6	I2_TX5	I2_TX4	I2_TX3	I2_TX2	I2_TX1	I2_TX0
0AH	Actual Flash	IFL_ACT7	IFL_ACT6	IFL_ACT5	IFL_ACT4	IFL_ACT3	IFL_ACT2	IFL_ACT1	IFL_ACT0
0BH	Minimum Flash	IFL_MIN7	IFL_MIN6	IFL_MIN5	IFL_MIN4	IFL_MIN3	IFL_MIN2	IFL_MIN1	IFL_MIN0
0CH	LED1 Torch	I1_TOR7	I1_TOR6	I1_TOR5	I1_TOR4	I1_TOR3	I1_TOR2	I1_TOR1	I1_TOR0
0DH	LED2 Torch	I2_TOR7	I2_TOR6	I2_TOR5	I2_TOR4	I2_TOR3	I2_TOR2	I2_TOR1	I2_TOR0
0EH	Fault Indication	FT_VBATL	FT_OVP	FT_VOSC	FT_LEDSC	FT_OTP	FT_TO	FT_TX	FT_IDC
0FH	Fault Indication	TBK1	TBK0	NA	NA	BAL_1AB2	BAL_2AB1	FT_LEDHOT	FT_LEDOP

Table 2: Chip ID Register

Addr: 0x00				
Bit	Bit Name	Access	Default	Description
2:0	REV_ID	R	001	Revision ID
7:3	DEV_ID	R	00011	Device ID

Table 3: Mode Setting Register

Addr: 0x01				
Bit	Bit Name	Access	Default	Description
7	STR_LV	RW	1	Flash mode trigger mode with strobe signal. 0 = edge trigger 1 = level trigger
6	STR_MOD	RW	1	Strobe enable bit. 0 = software enable 1 = hardware enable
5	STR_POL	RW	1	Strobe signal input active polarity. 0 = active low 1 = active high
4	LED1_EN	RW	0	LED1 current source enable bit. 0 = LED current source disable bit 1 = enable
3	LED2_EN	RW	0	LED2 current source enable bit. 0 = LED current source disable bit 1 = enable
2:1	LED_MOD	RW	00	Device mode setting bits. 00 = torch mode 01 = indicator mode 10 = assist light mode 11 = flash mode
0	5V_MOD	RW	0	5V DC output enable bit. 0 = disable 1 = enable

Table 4: Peak Current Setting Register

Addr: 0x02				
Bit	Bit Name	Access	Default	Description
7:5	NTC_WD	RW	000	NTC detection window. 000 = disabled 001 = 0.6V; 010 = 0.67V; 011 = 0.74V; 111 = 1.02V; 0.07V/step
4:3	IL_PEAK	RW	01	Inductor current limit setting bits. 00 = 2A, 01 = 2.5A, 10 = 3.5A, 11 = 4.5A
2	FS_SD	RW	0	Disable the switching frequency stretching down from 1MHz if VIN is close to VOUT. 0 = enable Fsw stretch-down function 1 = disable Fsw stretch-down function
1	BAL_ON	RW	0	LED load balance enable bit. 0 = LED voltage mismatch auto-balance disabled 1 = LED voltage mismatch auto-balance enabled
0	NA	RW	NA	Reserved

Table 5: Flash Timer Setting Register

Addr: 0x03				
Bit	Bit Name	Access	Default	Description
7:4	FL_TIM	RW	0001	Flash timer setting bits. 50ms to 800ms, 50ms/step. 0000 = 50ms; 0001 = 100ms; 1111 = 800ms
3	LED_SD	RW	0	LED_MOD and LED1/2_EN resetting control bit. 0 = reset LED_MOD and LED1/2_EN to default value after flash or torch 1 = no reset
2	LEDT_SD	RW	0	LED_MOD and LED1/2_EN resetting control bit when an NTC fault occurs. 0 = no reset and device continues 1 = reset and device stops
1:0	SW_FS	RW	00	Switching frequency setting bits. 00 = 4MHz; 01 = 3MHz; 10 = 2MHz; 11 = 1MHz

Table 6: Low Battery Voltage Setting Register

Addr: 0x04				
Bit	Bit Name	Access	Default	Description
7:5	VBL_RUN	RW	111	Low battery voltage setting bits. If VIN drops below this voltage during start-up, the current ramping stops. If the current is decreased during the flash current pulse until VIN is higher than its threshold, it works only in flash mode. 000 = 3V; 001 = 3.1V; 110 = 3.6V; 111 = disabled; 0.1V per step
4	VBL_SD	RW	1	Action in low battery protection and flash mode. 1 = device disabled when VIN is less than the threshold set by VBL_RUN before flash 0 = enable and current ramps up to current set by I_TX
3:0	IL_DC	RW	0100	Input DC current limit setting bits. 1A to 4.2A. 1A to 3A: 250mA/step, 0000 = 1A; 1000 = 3A; >3A: 300mA/step, 1001 = 3.3A, 1100 = 4.2A

Table 7: Indicator Register

Addr: 0x05				
Bit	Bit Name	Access	Default	Description
7	LED_OTAD	RW	0	Adaptive thermal flash current control bit. 1 = current reduces to the current set by I_TX when Tj > 130°C 0 = disable
6:4	TUP_I	RW	001	Current ramps up time per step. 000 = 8µs; 001 = 7µs, 111 = 1µs/step
3:2	VTH_PAS	RW	01	These two bits define the threshold when Fsw drops to 1MHz or switches to pass mode from boost mode. 00 = 300mV, 01 = 450mV, 10 = 600mV, 11 = 750mV
1:0	INDI_PWM	RW	00	PWM duty cycle of 31.5kHz in indicator mode. 00 = 2/16; 01 = 3/16; 10 = 4/16; 11 = 5/16

Table 8: LED1 Flash Current Setting Register

Addr: 0x06				
Bit	Bit Name	Access	Default	Description
7:0	I1_FL	RW	00110011	LED1 flash current setting bits. 0 to 1500mA, 5.88mA/step. 00000000 = 0mA, 11111111 = 1500mA (default 00110011 = 300mA)

Table 9: LED2 Flash Current Setting Register

Addr: 0x07				
Bit	Bit Name	Access	Default	Description
7:0	I2_FL	RW	00110011	LED2 flash current setting bits. 0 to 1500mA, 5.88mA/step. 00000000 = 0mA, 11111111 = 1500mA (default 00110011 = 300mA)

Table 10: LED1 TX Current Setting Register

Addr: 0x08				
Bit	Bit Name	Access	Default	Description
7:0	I1_TX	RW	00110011	Defines the flash current in flash mode if TX is high. 0 to 1500mA, 5.88mA/step. 00000000 = 0mA, 11111111 = 1500mA (default 00110011 = 300mA)

Table 11: LED2 TXM Current Setting Register

Addr: 0x09				
Bit	Bit Name	Access	Default	Description
7:0	I2_TX	RW	00110011	Defines the flash current in flash mode if TX is high. 0 to 1500mA, 5.88mA/step. 00000000 = 0mA, 11111111 = 1500mA (default 00110011 = 300mA)

Table 12: Actual Flash LED Current Register

Addr: 0x0A				
Bit	Bit Name	Access	Default	Description
7:0	IFL_ACT	R	00000000	The actual flash current in flash mode. 0 to 1500mA, 5.88mA/step. 00000000 = 0mA, 11111111 = 1500mA

Table 13: Minimum Flash LED Current Register

Addr: 0x0B				
Bit	Bit Name	Access	Default	Description
7:0	IFL_MIN	R	00000000	The minimum flash current caused by a low battery voltage current reduction in flash mode. 0 to 1500mA, 5.88mA/step. 00000000 = 0mA, 11111111 = 1500mA

Table 14: LED1 Torch Current Setting Register

Addr: 0x0C				
Bit	Bit Name	Access	Default	Description
7:0	I1_TOR	RW	00010101	LED1 torch current setting bits. 0 to 1500mA, 5.88mA/step. 00000000 = 0mA, 11111111 = 1500mA (default 00010101 = 123mA)

Table 15: LED2 Torch Current Setting Register

Addr: 0x0D				
Bit	Bit Name	Access	Default	Description
7:0	I2_TOR	RW	00010101	LED2 torch current setting bits. 0 to 1500mA, 5.88mA/step. 00000000 = 0mA, 11111111 = 1500mA (default 00010101 = 123mA)

Table 16: Fault Indication Register

Addr: 0x0E				
Bit	Bit Name	Access	Default	Description
7	FT_VBATL	R	0	Low battery voltage fault bit. 0 = no fault. 1 = fault.
6	FT_OVP	R	0	Output over-voltage fault bit. 0 = no fault. 1 = fault.
5	FT_VOOSC	R	0	VOUT-GND short fault bit. 0 = no fault. 1 = fault.
4	FT_LEDSC	R	0	LED short fault bit. 0 = no fault. 1 = fault.
3	FT_OTP	R	0	Junction over-temperature fault bit. 0 = no fault. 1 = fault.
2	FT_TO	R	0	Flash time-out flag bit. 0 = no fault. 1 = flash timer is triggered with hardware and level-trigger modes.
1	FT_TX	R	0	TX flag bit. 0 = no fault. 1 = TX is pulled high.
0	FT_IDC	R	0	Input DC current limit fault bit. 0 = no fault. 1 = fault.

Table 17: Fault Indication Register

Addr: 0x0F				
Bit	Bit Name	Access	Default	Description
7:6	TBK0-1	R/W	01	Blinking time setting bits in indicator mode. TBK [0-1] = 00, no blinking, LED constant on TBK [0-1] = 01, Tblink = 128ms (default) TBK [0-1] = 10, Tblink = 256ms TBK [0-1] = 11, Tblink = 512ms
5:4	NA	R	NA	Reserved.
3	BAL_1AB2	R	0	1 = VLED1 > VLED2 + 125mV 0 = VLED1 < VLED2 + 125mV
2	BAL_2AB1	R	0	1 = VLED2 > VLED1 + 125mV 0 = VLED2 < VLED1 + 125mV
1	FT_LEDHOT	R	0	NTC fault bit. 0 = no fault. 1 = fault.
0	FT_LEDOP	R	0	LED open fault bit. 0 = no fault. 1 = fault.

APPLICATION INFORMATION

Selecting the Input Capacitor

The input capacitor reduces the surge current drawn from the input supply and the switching noise from the device. The input capacitor impedance at the switching frequency should be less than the input source impedance to prevent the high-frequency switching current from passing through to the input. Ceramic capacitors with X5R or X7R dielectrics are recommended because of their low ESR and small temperature coefficients. A capacitor with a higher value is recommended to reduce input voltage ripple and noise. For most applications, a 10µF ceramic capacitor is sufficient.

Selecting the Inductor

The converter requires an inductor to supply a higher output voltage while being driven by the input voltage. A larger value inductor generates less ripple current, resulting in a lower peak inductor current and less stress on the internal N-channel MOSFET. However, the larger value inductor has a larger physical size, a higher series resistance, and a lower saturation current.

Choose an inductor that does not saturate under the worst-case load conditions. Select the minimum inductor value to ensure that the boost converter works in continuous conduction mode (CCM) with high efficiency and good EMI performance.

The required inductance value can be calculated with Equation (1) and Equation (2):

$$L \geq \frac{\eta \times V_{OUT} \times D \times (1-D)^2}{2 \times f_{SW} \times I_{LOAD}} \quad (1)$$

$$D = 1 - \frac{V_{IN}}{V_{OUT}} \quad (2)$$

Where V_{IN} and V_{OUT} are the input and output voltages, f_{SW} is the switching frequency, I_{LOAD} is the LED load current, and η is the efficiency.

The switching current is used for the peak current mode control. To avoid hitting the current limit, the worst-case inductor peak current should be less than 80% of the current limit (I_{LIM}). For most applications, a 0.47µH~2µH inductor is sufficient.

Selecting the Output Capacitor

The output capacitor keeps the output voltage ripple small and ensures feedback loop stability. The output capacitor impedance must be low at the switching frequency. Ceramic capacitors with X7R dielectrics are recommended because of their low ESR characteristics. Care must be taken to ensure that the ceramic capacitance is dependent on the voltage rating since the DC bias voltage and the value can lose as much as 50% of its capacitance at its rated voltage rating. Please leave enough of a voltage rating margin when selecting the component, as a capacitance that is too low causes loop instability. For most applications, a 10µF ceramic capacitor is sufficient.

PCB Layout Guidelines

Efficient PCB layout is critical for stable operation. For best results, refer to Figure 17 and follow the guidelines below.

1. Place the input capacitor as close to VIN as possible.
2. Use wider copper traces for the input, output, and GND connecting wire to improve thermal performance.
3. Place the GND via as close to the output and input capacitor as possible to improve thermal performance.

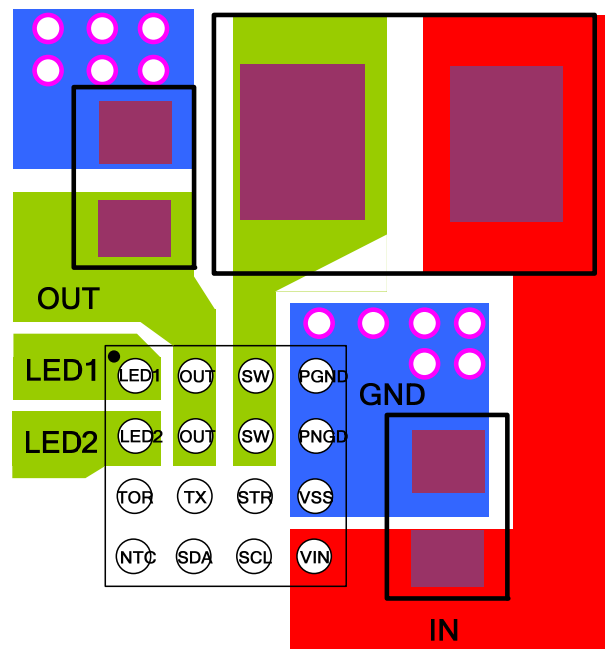
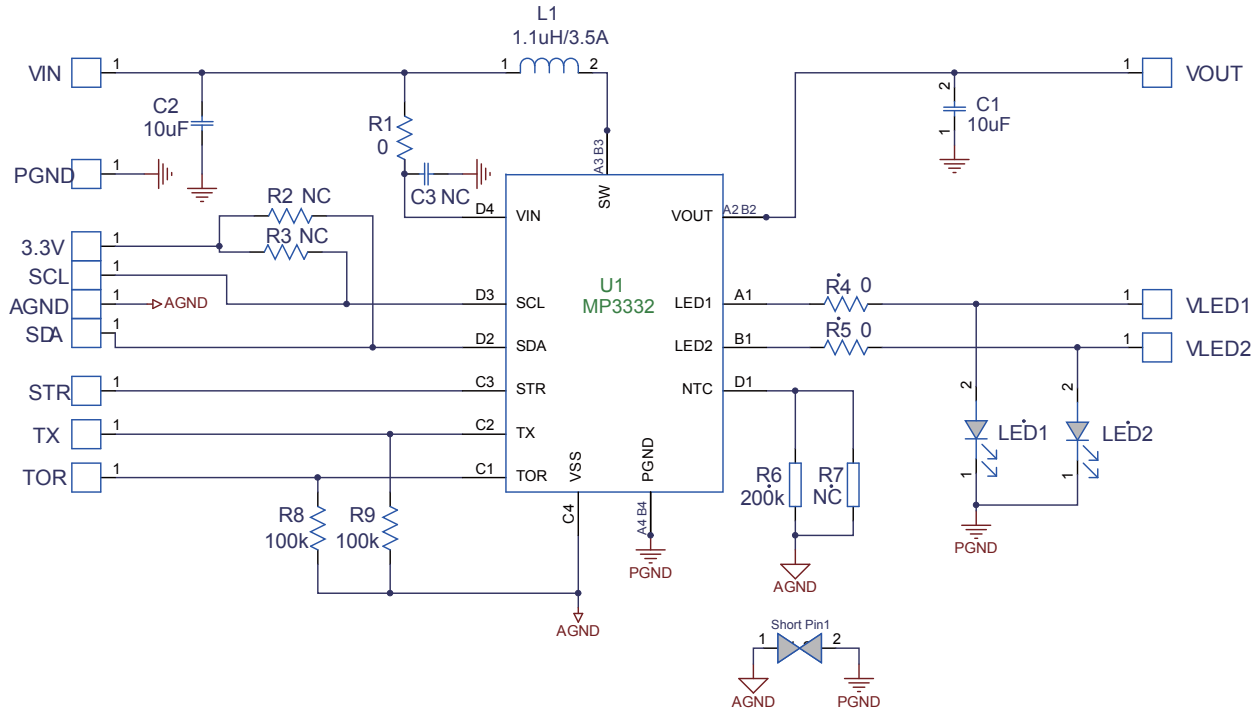
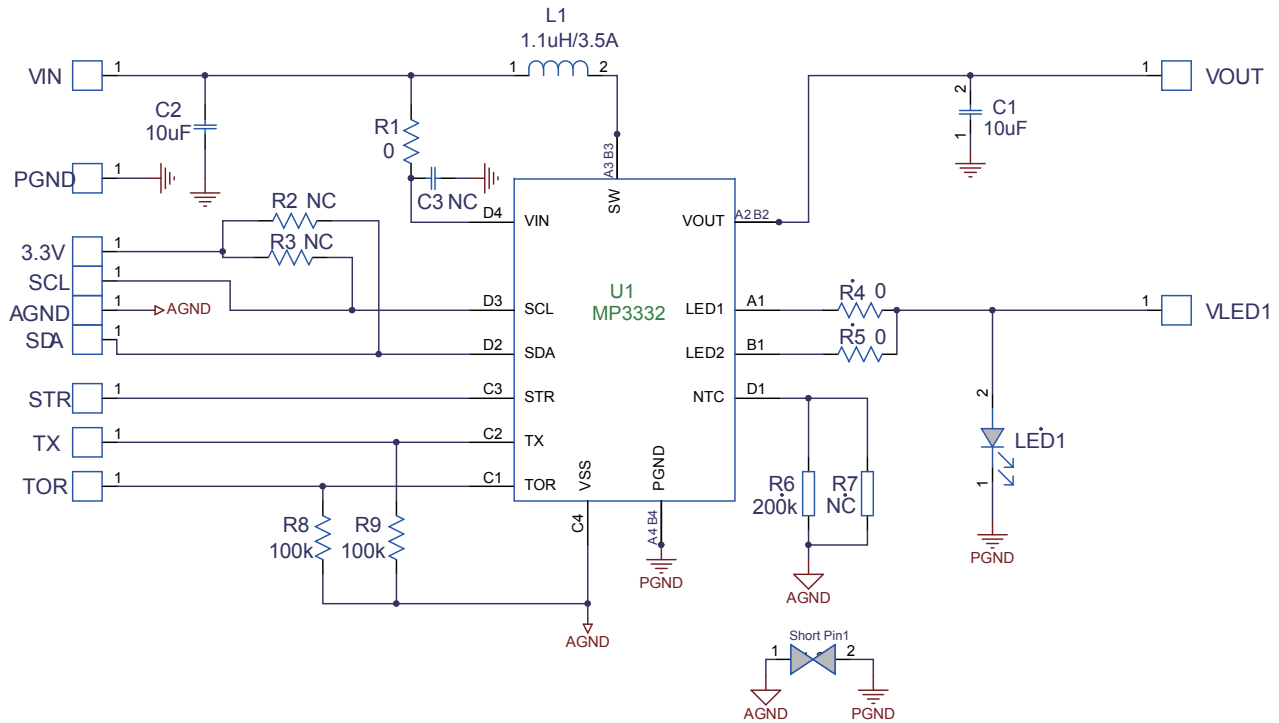
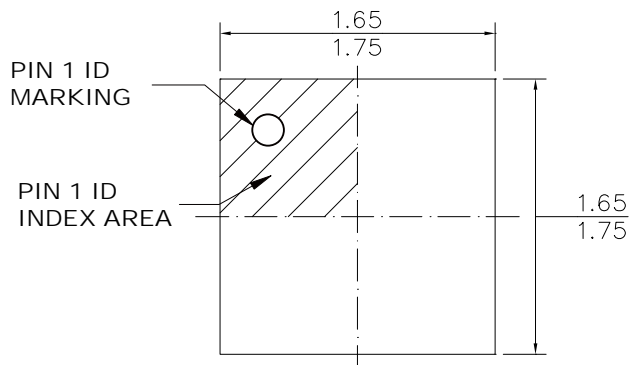

Figure 17: Recommended Layout

TYPICAL APPLICATION CIRCUITS

Figure 18: Dual Channel Application Circuit

Figure 19: Single LED Application Circuit

PACKAGE INFORMATION

WLCSP-16 (1.7mmx1.7mm)

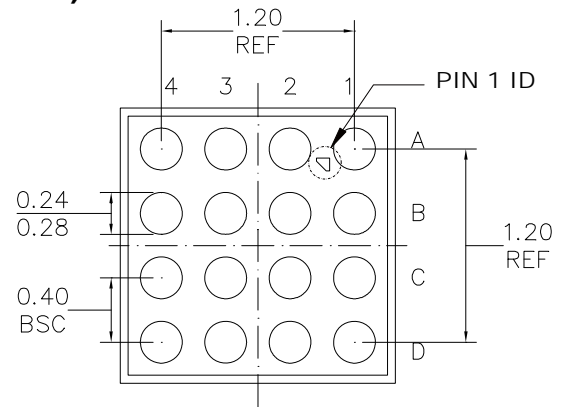

TOP VIEW



BOTTOM VIEW

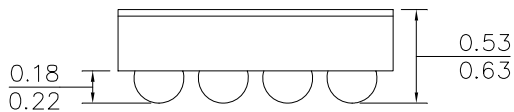

SIDE VIEW

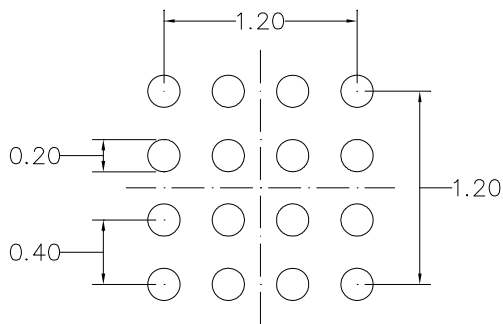

RECOMMENDED LAND PATTERN

NOTE:

- 1) ALL DIMENSIONS ARE IN MILLIMETERS.
- 2) BALL COPLANARITY SHALL BE 0.05 MILLIMETER MAX.
- 3) JEDEC REFERENCE IS MO-211.
- 4) DRAWING IS NOT TO SCALE.

NOTICE: The information in this document is subject to change without notice. Please contact MPS for current specifications. Users should warrant and guarantee that third party Intellectual Property rights are not infringed upon when integrating MPS products into any application. MPS will not assume any legal responsibility for any said applications.